

Liberator Hand Truck Assembly Instructions

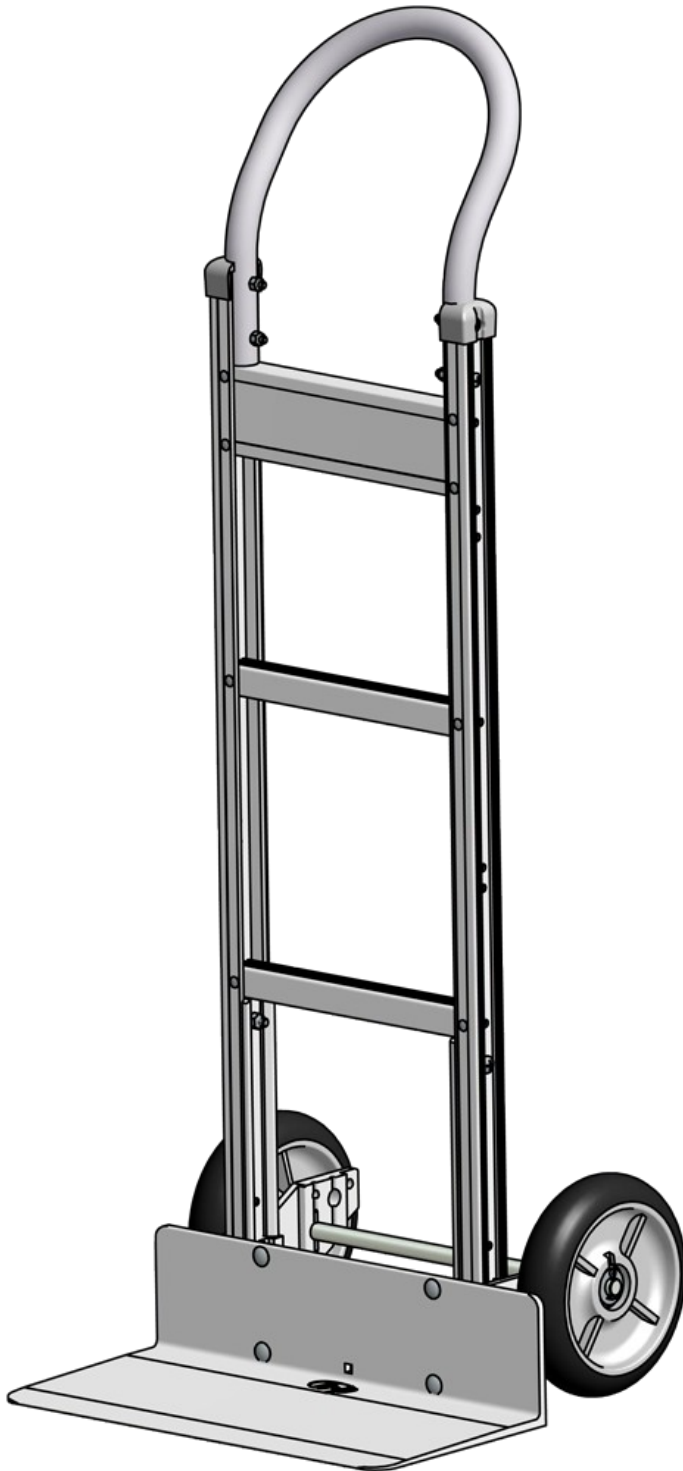

Table of Contents:

Hand Truck Components.....	2
Lower Hand Truck Assembly.....	3-5
Handle Assembly	6

*Handle, frame, nose pate, and wheels will vary based on the options selected at the time of purchase.

www.bpmfg.com

8051 East Boon Road | Cadillac, MI 49601

(800) 334-7141

b&p Manufacturing
Engineered Delivery Products

The following guide is brought to you by



C.P. LAUMAN COMPANY
SUPPLIER OF PREMIUM CASTERS, WHEELS, HAND TRUCKS
& CARGO CONTROL EQUIPMENT
ESTABLISHED 1941

Visit us online at cplauman.com to view our wide selection of casters, wheels, hand trucks, & cargo control equipment.

Liberator Hand Truck Components

Item	Description	Qty.	Part No.
A	Handle	1	Various
B	Frame	1	Various
C	Nose Plate	1	Various
D	Wheel	2	Various
E	Axle, Long—10" Wheels or Axle, Short—8" Wheels	1	2001-201 or 2001-211
F	Side Channel Reinforcement	2	2002-733
G	Axle Bracket, LH	1	2001-701
H	Axle Bracket, RH	1	2001-702
I	End Cap	2	8226-001
J	Hex Head Bolt, 5/16"-18 x 2" or Hex Head Bolt, 5/16"-18 x 2-1/4"	4	8007-022 or 8007-016
K	Lock Nut, 5/16"-18	6	8001-005
L	Pan Head Screw, 1/4" 20 x 1-3/4"	4	8068-003
M	Lock Nut, 1/4"-20	4	8001-004
N	Pan Head Screw, 5/16"-18 x 1-1/4"	2	8068-005
O	Cotter Pin	2	8008-001
P	Washer, 5/8"	4	8003-010
Q	Thin Washer, 5/8"	4	8078-010
R	Nose Plate Mounting Bracket	2	2001-740
S	Carriage Bolt, 5/16"-18 x 1"	4	8005-009
T	Lock Nut, 5/16"-18	4	8001-005

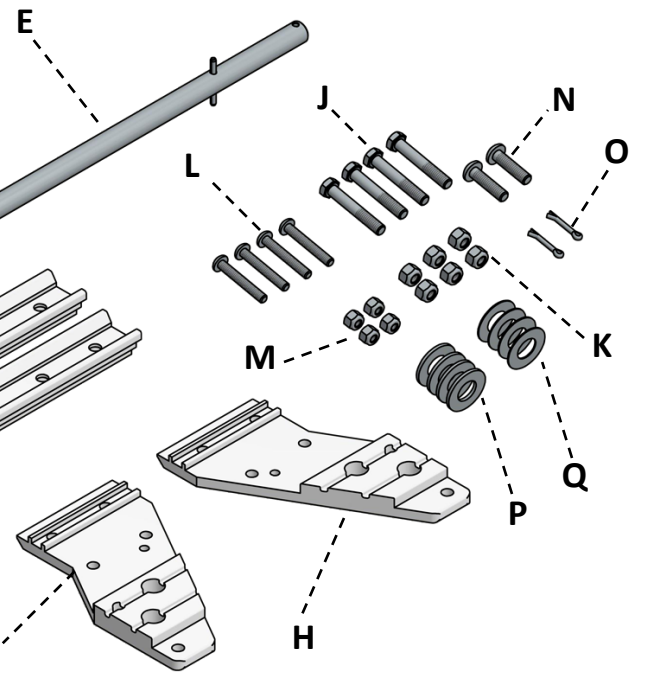
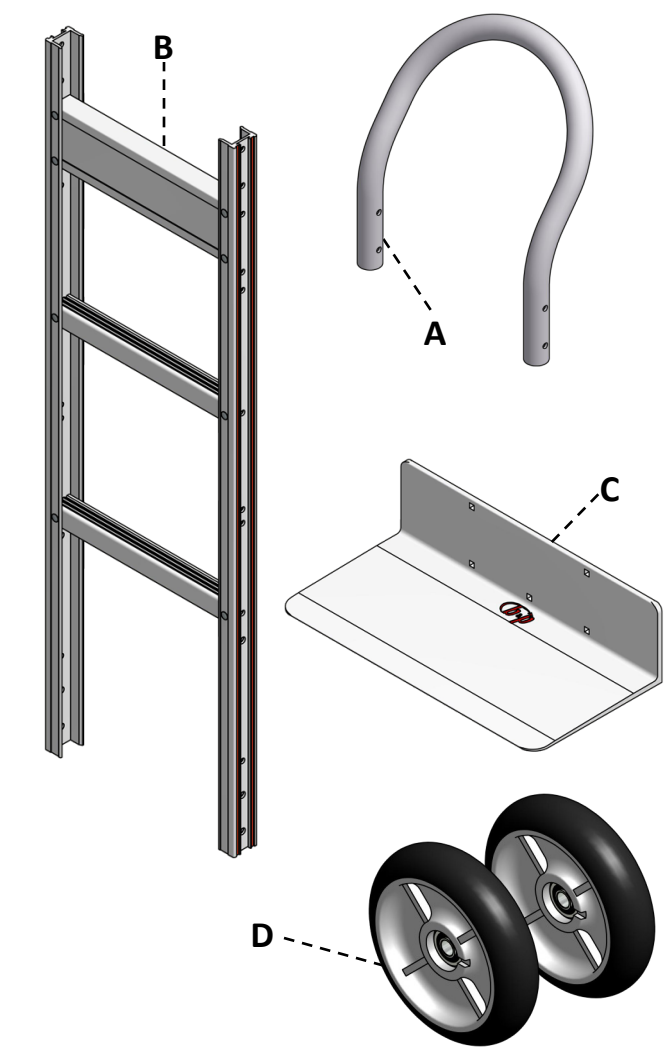

Tools Required:

- (2) 1/2" wrench/socket
- (1) #2 Phillips screwdriver
- (1) 7/16" wrench/socket
- (1) Needle nose pliers

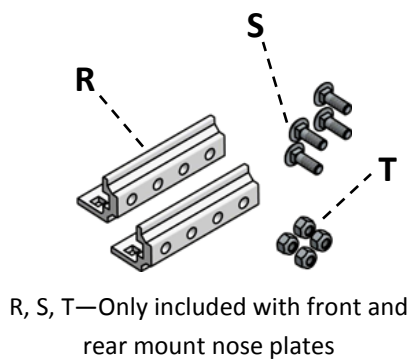

Lower Hand Truck Assembly

1. To begin start with the frame (B) and attach a side channel reinforcement (F) to the inner channel of each frame leg, securing with a 5/16"-18 x 1-1/4" pan head screw (N) and nut (K) thru the top hole of the reinforcement. Do not tighten completely.
2. Next attach the nose plate (C) to the frame. Slide the frame over the nose plate mounting brackets. If included attach nose plate mounting brackets (R) to the front of a rear mount nose plate or the back of a front mount nose plate with 5/16"-18 carriage bolts (S) and nuts (T) before sliding the frame on the nose plate. Nose plate assembly differs based on the type of nose plate purchased. Refer to the images below to determine the orientation of the nose plate fasteners.

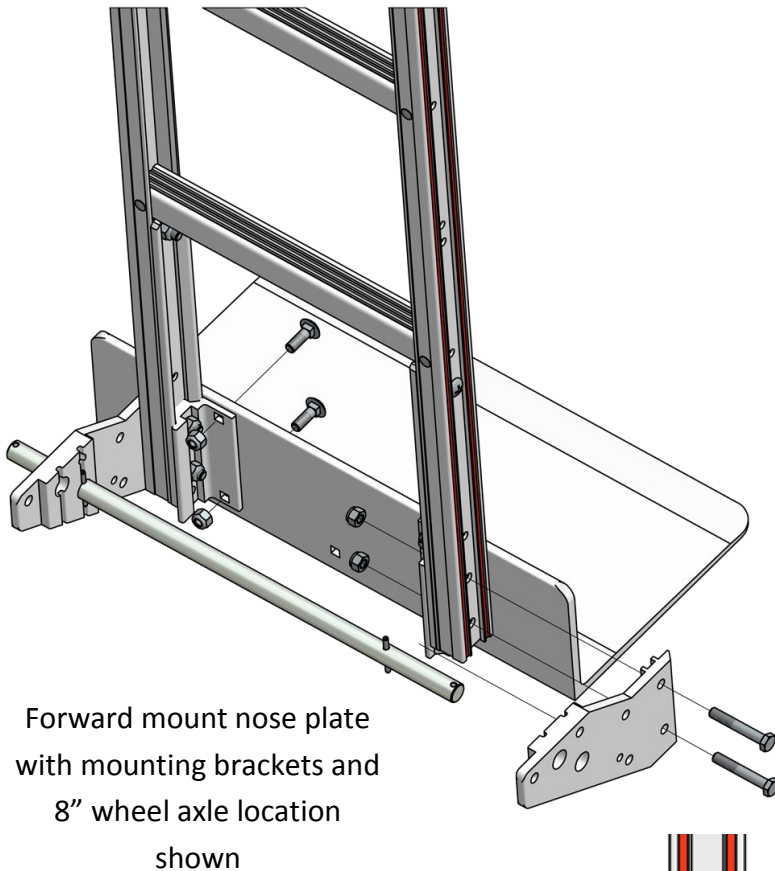
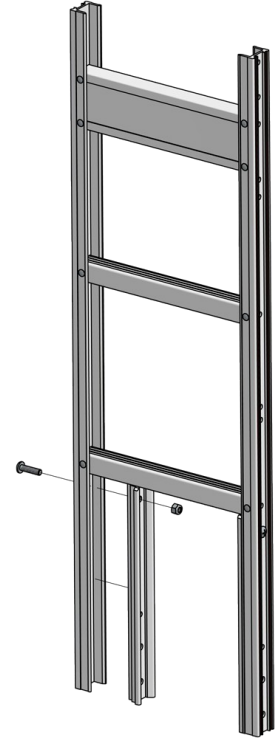

3. Place the left (G) and right (H) axle brackets onto the frame passing thru the nose plate and secure with 5/16"-18 hex bolts (J) and nuts (K). Install one side at a time, placing the axle (E) between the brackets and aligning the spring pins with the slots in the brackets. Note the axle hole location differs for 8" and 10" wheels. Tighten all fasteners.

Refer to page 4 for additional nose plate configurations

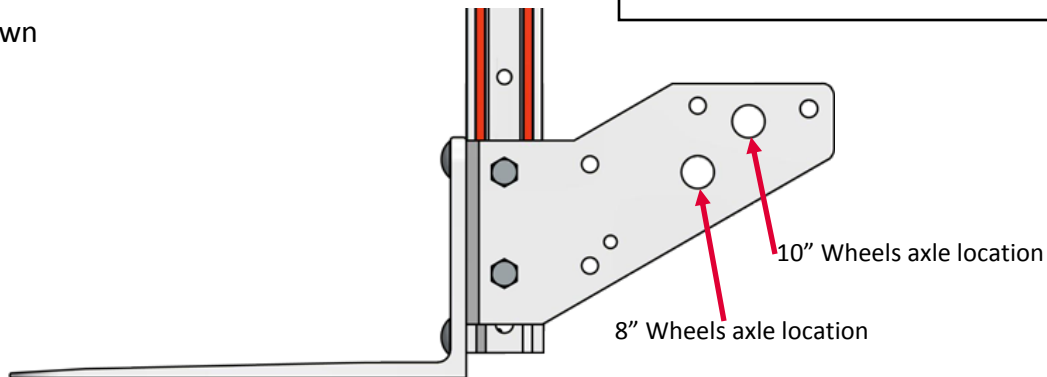

Lower Hand Truck Assembly

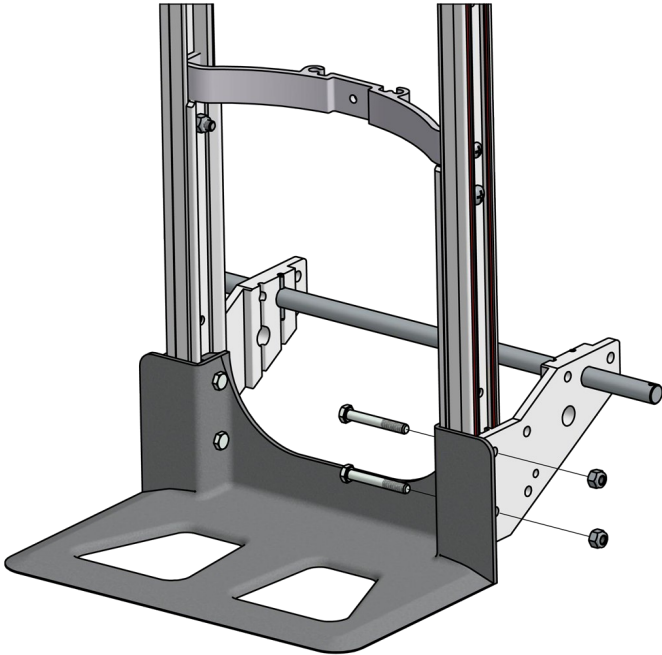

Cast Aluminum Recessed Heel

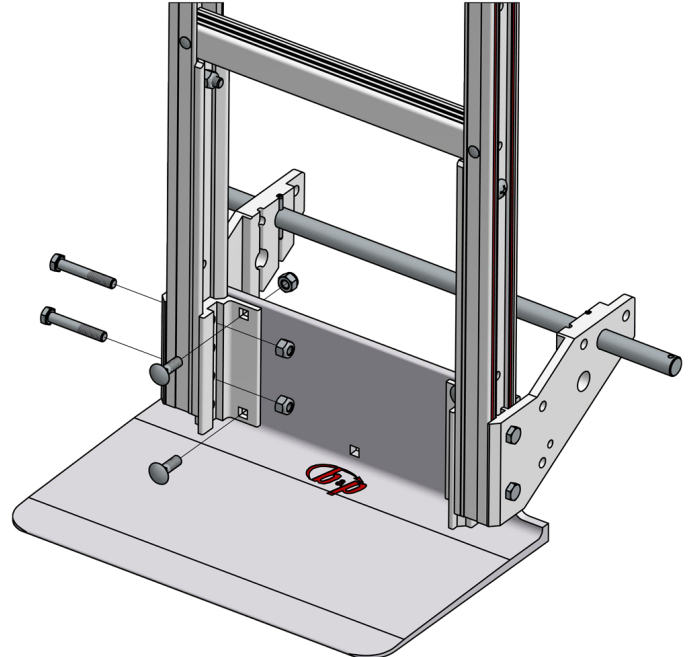

Extruded Aluminum Rear Mount
with Mounting Brackets

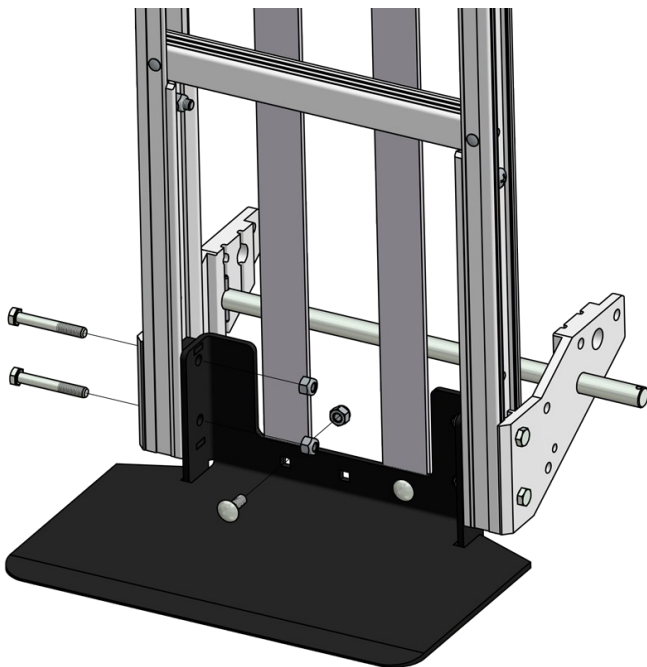

Steel Recessed Heel

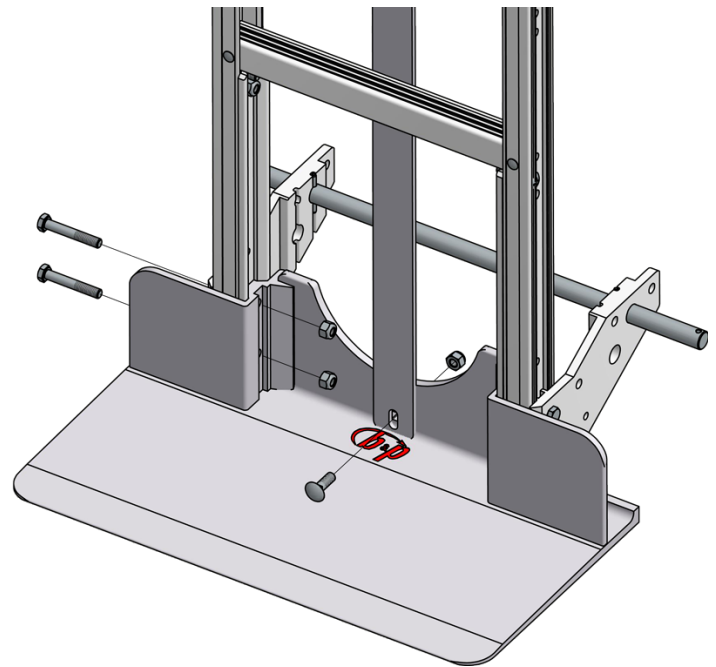

Extruded Aluminum Recessed Heel

4. If your frame has a vertical strap remove the bolt and nut from the bottom of the strap prior to assembly and set aside. Test fit the frame to the nose plate prior to installing fasteners to ensure that the orientation of the strap (front to back) aligns with the nose plate hole(s). After the nose plate is assembled to the frame attach the strap to the nose plate with the hardware previously set aside.

Lower Hand Truck Assembly

5. Install the wheel assemblies (D). Place two washers (P) onto the axle followed by the wheel. Place two thin washers (Q) on the axle and secure to the axle with a cotter pin (O). Repeat for opposite side.

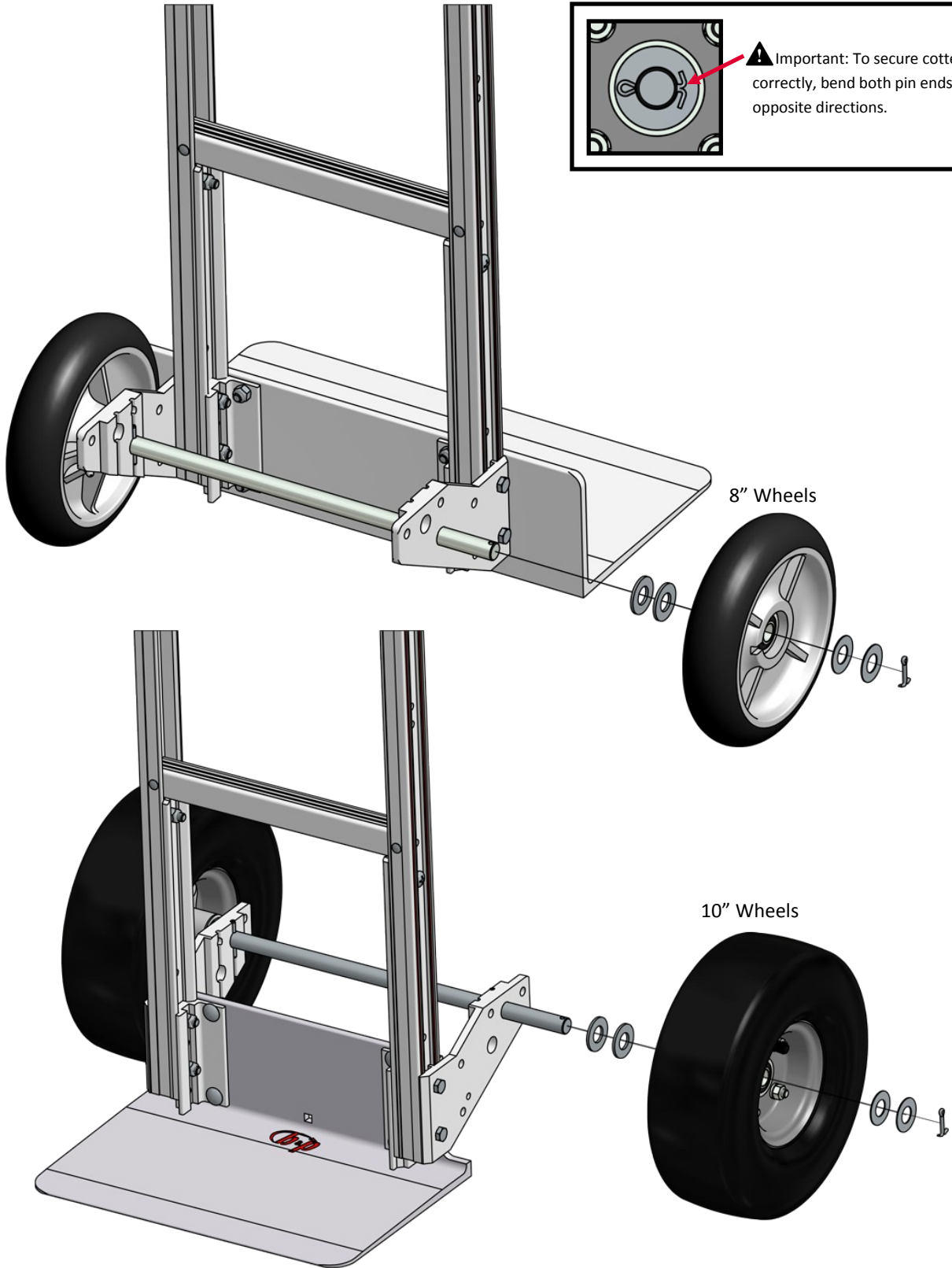

Handle Assembly

6. Slide handle (A) into the top of the hand truck frame. Cap ends of the frame with end caps (I) and secure with 1/4"-20 x 1-3/4" screws (L) and lock nuts (M).

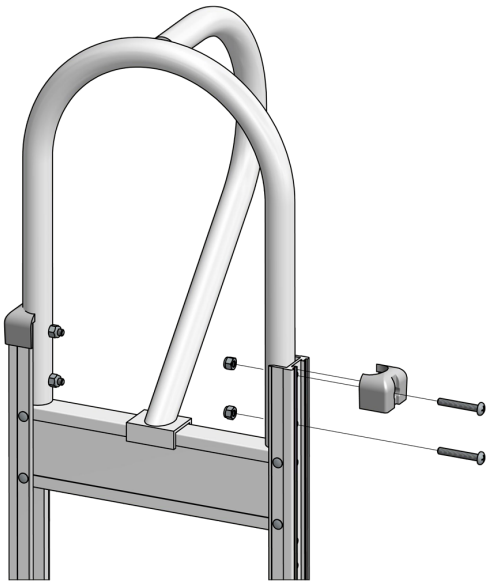

Vertical Grip Handles

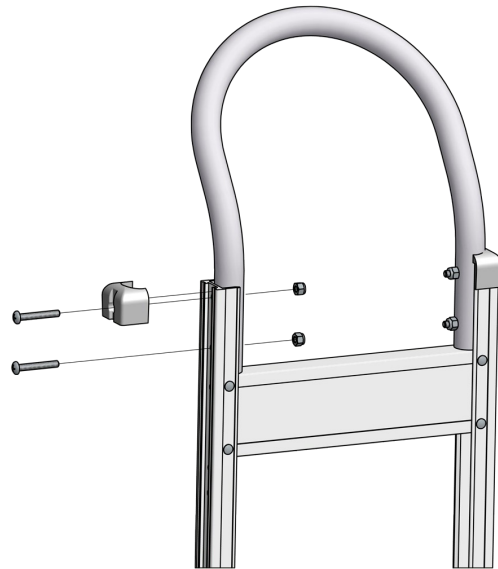

Vertical Grip Handles

Double Vertical Grip

Single Grip

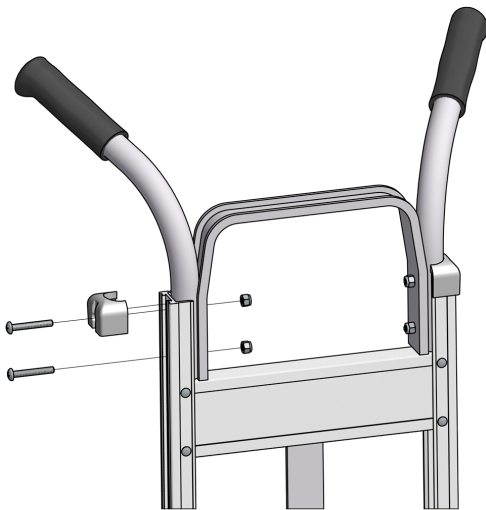

Double Grip Handle

6. For vertical grip handles with a curved back frame remove nuts and bolts from the center handle prior to installation and set aside. Slide the handle into the frame and fasten as listed in step 5. Then attach the handle mount plate to the top cross member with the hardware previously set aside.

*If additional options have been ordered, please refer to the options individual instructions for assembly information.

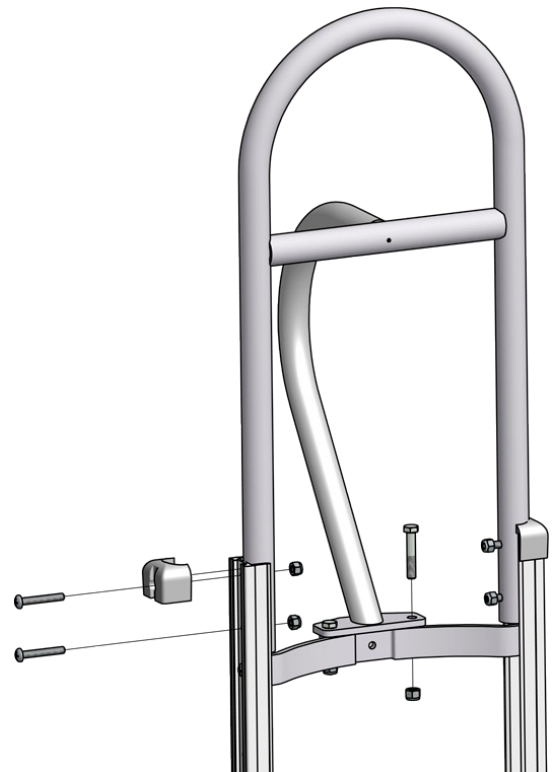

Curved back frame