

# Jr. Liberator Convertible Hand Truck

## Assembly Instructions

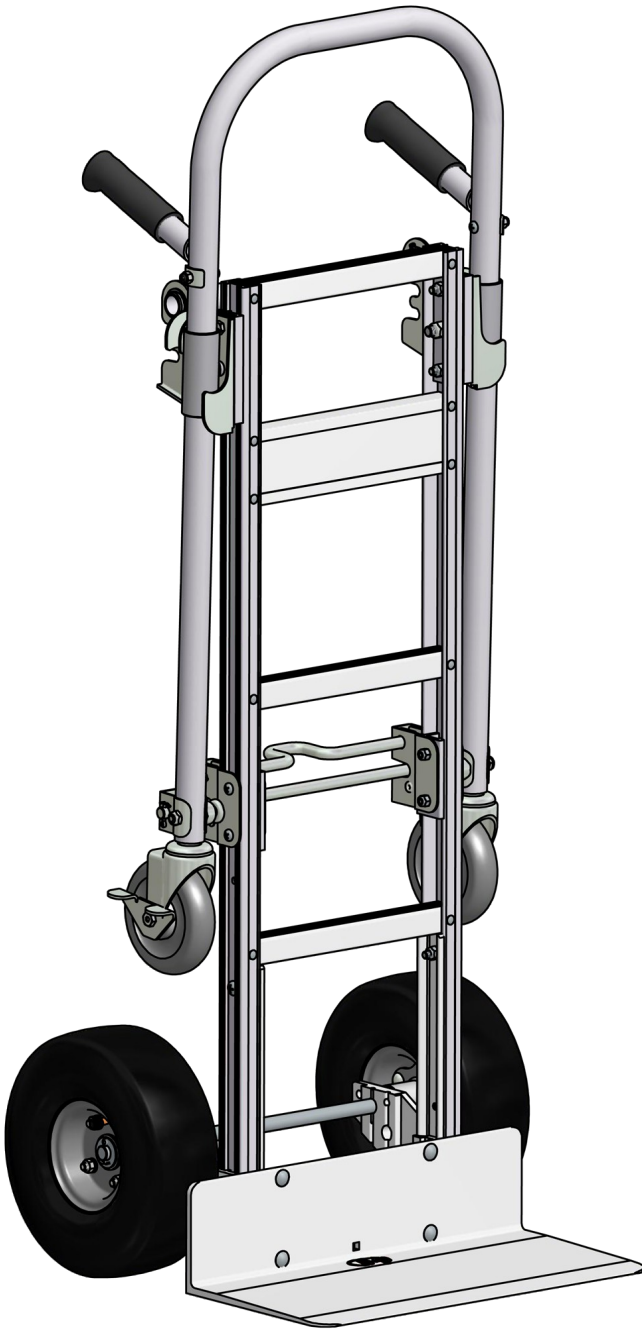

\*Frame, nose plate, and wheels will vary based on the options selected at the time of purchase.

Item	Description	Qty.	Part No.
A	Frame, JR	1	Various
B	Nose Plate	1	Various
C	Wheel	2	Various
D	Axle, Long—10" Wheels	1	2001-201
E	Side Channel Reinforcement	2	2002-733
F	Axle Bracket, LH	1	2001-701
G	Axle Bracket, RH	1	2001-702
H	End Cap	2	8226-001
I	Hex Head Bolt, 5/16"-18 x 2" or Hex Head Bolt, 5/16"-18 x 2-1/4"	4	8007-022 or 8007-016
J	Lock Nut, 5/16"-18	6	8001-005
K	Pan Head Screw, 1/4"-20 x 1-3/4"	8	8068-003
L	Lock Nut, 1/4"-20	12	8001-004
M	Pan Head Screw, 5/16"-18 x 1-1/4"	2	8068-005
N	Cotter Pin	2	8008-001
O	Washer, 5/8"	4	8003-010
P	Thin Washer, 5/8"	4	8078-010
Q	Nose Plate Mounting Bracket	2	2001-740
R	Carriage Bolt, 5/16"-18 x 1"	4	8005-009
S	Lock Nut, 5/16"-18	4	8001-005

[www.bpmfg.com](http://www.bpmfg.com)

8051 East Boon Road | Cadillac, MI 49601

(800) 334-7141

**b&p Manufacturing**  
Engineered Delivery Products

The following guide is brought to you by



**C.P. LAUMAN COMPANY**  
SUPPLIER OF PREMIUM CASTERS, WHEELS, HAND TRUCKS  
& CARGO CONTROL EQUIPMENT  
*ESTABLISHED 1941*

Visit us online at [cplauman.com](http://cplauman.com) to view our wide selection of casters, wheels, hand trucks, & cargo control equipment.

## Jr. Liberator Convertible Hand Truck Components

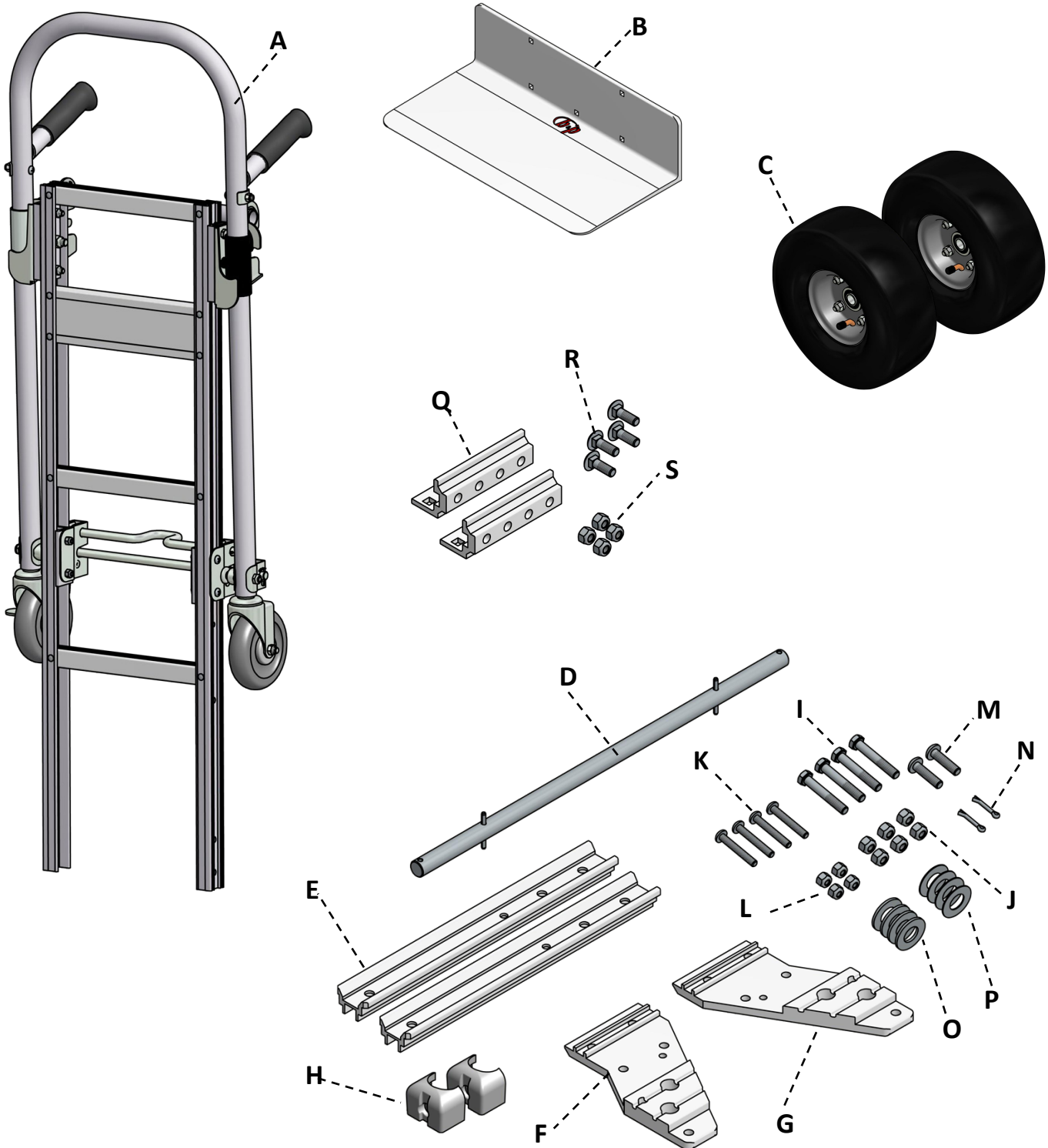

### Tools Required:

- (2) 1/2" wrench/socket
- (1) 7/16" wrench/socket
- (1) #2 Phillips screwdriver
- (1) Needle nose pliers

Q, R, S —Only included with front mount nose plates

Unused items that may be discarded:

- (H) End caps, 2 each
- (K) 1/4"-20 x 1-3/4" screws, 4 each
- (L) 1/4"-20 Lock nuts, 4 each

## Jr. Liberator Convertible Assembly Instructions

1. To begin start with the frame (A) and attach a side channel reinforcement (E) to the inner channel of each frame leg, securing with a 5/16" -18 x 1-1/4" pan head screw (M) and nut (J) thru the top hole of the reinforcement. Do not tighten completely.
2. Next attach the nose plate (B) to the frame. Slide the frame over the nose plate mounting brackets. If included attach nose plate mounting brackets (Q) to the back of a front mount nose plate with 5/16" -18 carriage bolts (R) and nuts (S) before sliding the frame on the nose plate. Nose plate assembly differs based on the type of nose plate purchased. Refer to the image below and the images on page 4 to determine the orientation of the nose plate fasteners.

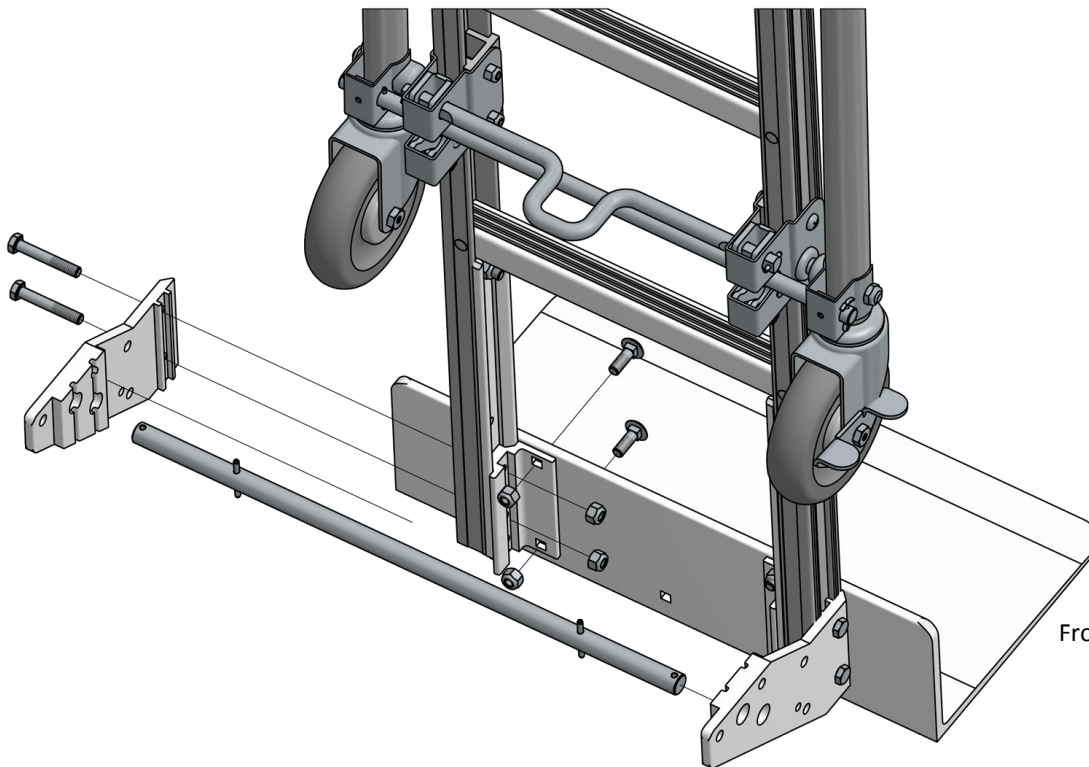

Front mount nose plate shown

3. Place the left (F) and right (G) axle brackets onto the frame passing thru the nose plate and secure with 5/16" -18 hex bolts (I) and nuts (J). Install one side at a time, placing the axle (D) between the brackets and aligning the spring pins with the slots in the brackets. Tighten all fasteners.

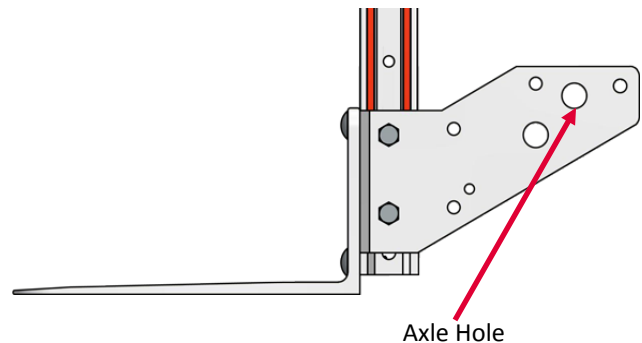

## Jr. Liberator Convertible Assembly Instructions

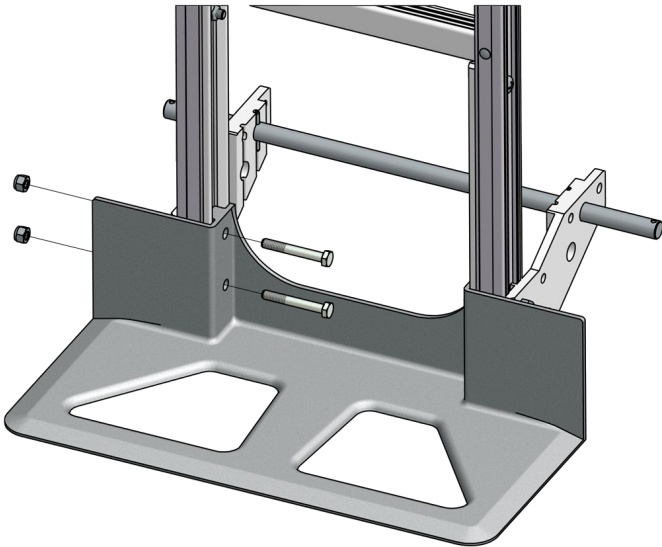

Cast Aluminum Recessed Heel

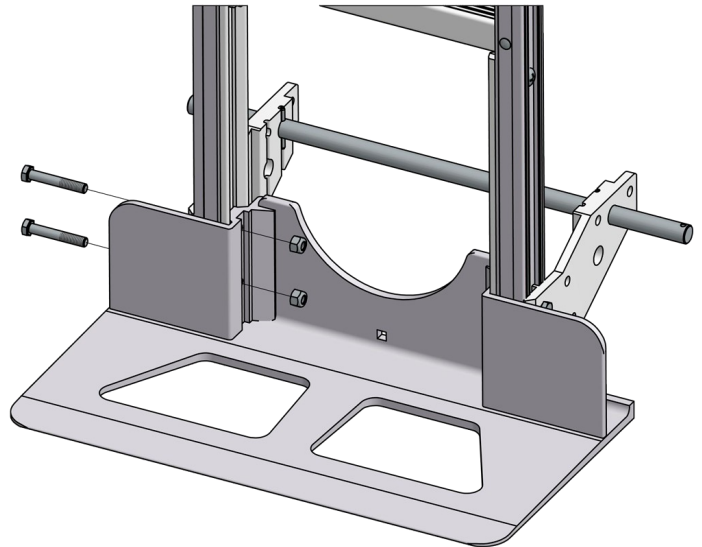

Extruded Aluminum Recessed Heel

4. If your frame has a vertical strap remove the bolt and nut from the bottom of the strap prior to assembly and set aside. After the nose plate is assembled to the frame attach the strap to the nose plate with the hardware previously set aside.
5. Install the wheel assemblies (C). Place two washers (O) onto the axle followed by the wheel. Place two thin washers (P) on the axle and secure to the axle with a cotter pin (N). Repeat for opposite side.

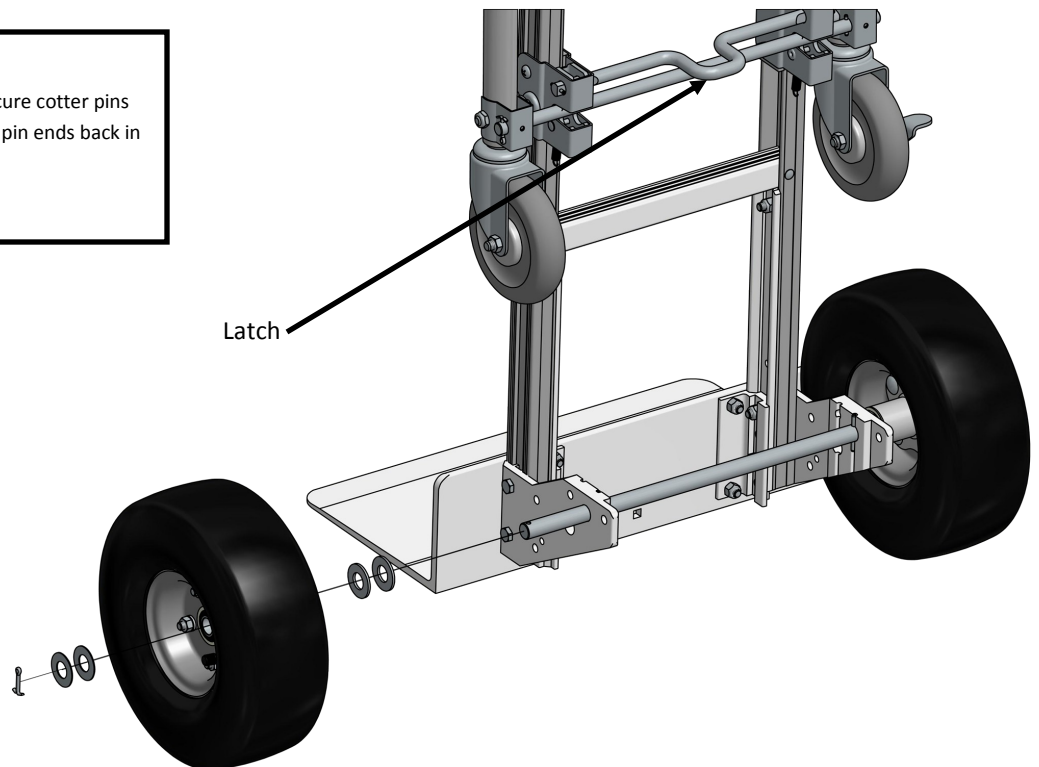
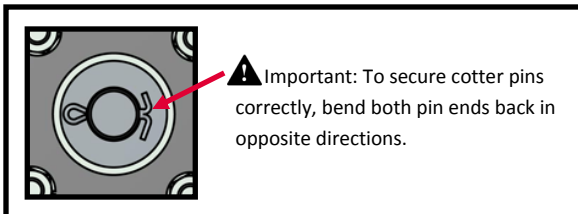

6. Lastly check all fasteners to be sure they are tight. Lay the convertible back into the platform truck position ensuring all components are working properly, then bring it back up into the hand truck position and test that the latch securely locks the swing arm in place.