

# DARCOR

CASTERS AND WHEELS

PRODUCT CATALOGUE



ERGONOMIC MOBILITY EXPERTS

# DARCOR PART NUMBERING SYSTEM

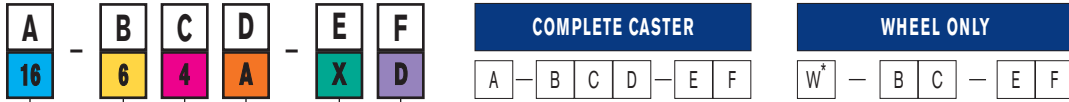

A	
INSTALLATION OPTIONS	
*	TOP PLATE *(SPECIFY PLATE NUMBER)
O*	GRIP RING STEM *(SPECIFY SIZE CODE)
L*	THREADED STEM *(SPECIFY SIZE CODE)
PB*	PIPE STEM *(SPECIFY SIZE CODE)
PC*	PIPE CAP *(SPECIFY SIZE CODE)
S*	SQUARE STEM *(SPECIFY SIZE CODE)
JA	STEM FOR METAL SOCKETS
WSA	WOOD LEG STEM C
*	CLINCHED SWIVEL *(SPECIFY SIZE)

B		C	
LOAD RANGE LBS./CASTER	SERIES DESIGNATION	WHEEL DIAMETER	STANDARD TOP PLATE
75	E2 ETERNITY II	2"	NA
125	53 CARPETMASTER	3"	NA
75-125	20 SERIES EXAMPLES = 22-22.5-23-24-25	2"-2.5"-3"-4"-5"	#12
200-400	30 SERIES EXAMPLES = 32-32.5	2"-2.5"-3"-4"	#16
175-400	60 SERIES EXAMPLES = 62.5-63-63.5-64-65	2.5"-3"-3.5"-4"-5"	#16
225-600	70 SERIES EXAMPLES = 73-74-75-76	3"-4"-5"-6"	#31
400-1000	400 SERIES EXAMPLES = 403-404-405-406-408	3"-4"-5"-6"-8"	#31
1350-2200	700 SERIES EXAMPLES = 705-706-708-710	5"-6"-8"-10"	#6
500-1800	KINGPINLESS EXAMPLES = KP406-KP408	6" - 8"	#31
1300-1800	800 SERIES EXAMPLES = 805-806-808-810	5"-6"-8"-10"	#8
1200-3500	900 SERIES EXAMPLES = 906-908-910-912	6"-8"-10"-12"	#6
2000-5000	5000 SERIES EXAMPLES = 5006-5008-5010-5012	6"-8"-10"-12"	#5000
5000-10000	5200 SERIES EXAMPLES = 5206-5208-5210-5212	6"-8"-10"-12"	#5200

D	
OPTIONS	
R	RIGID CASTER
B	BRAKE
F2	TWO POSITION SWIVEL LOCK
F4	FOUR POSITION SWIVEL LOCK
A	COMBINATION BRAKE AND 4 POSITION SWIVEL LOCK
S	SEALED SWIVEL WITH GREASE FITTINGS IN SWIVEL AND AXLE
G	GREASE FITTING IN AXLE ONLY

E	
BEARING TYPE	
T	ROLLER
P	PRECISION SEALED BALL BEARING
Y	TAPERED ROLLER
M	DELTRIN
OMIT PLAIN SLEEVE	

F	
TREAD MATERIAL	
D	NEOPRENE
SR	SUPER ROLL NEOPRENE
SE™	SOLID ELASTOMER
SX	SE EXTRA WEIGHT
U	URETHANE
LE	LOW EFFORT U
CI	SEMI-STEEL
H	HARD RUBBER
CV	V-GROOVE-SEMI-STEEL

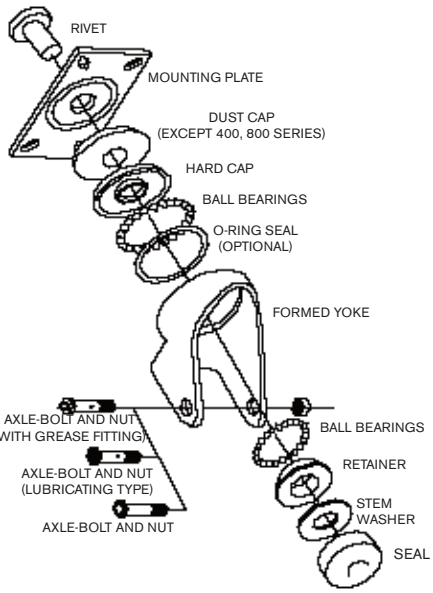
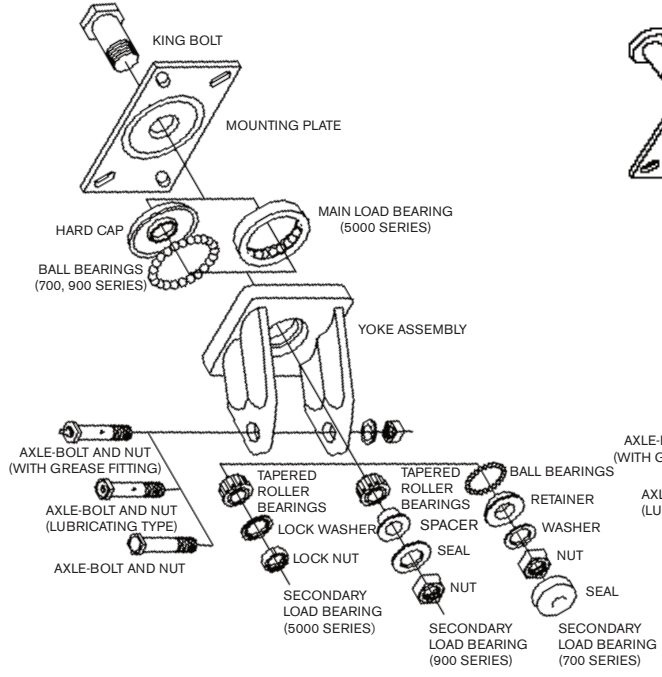
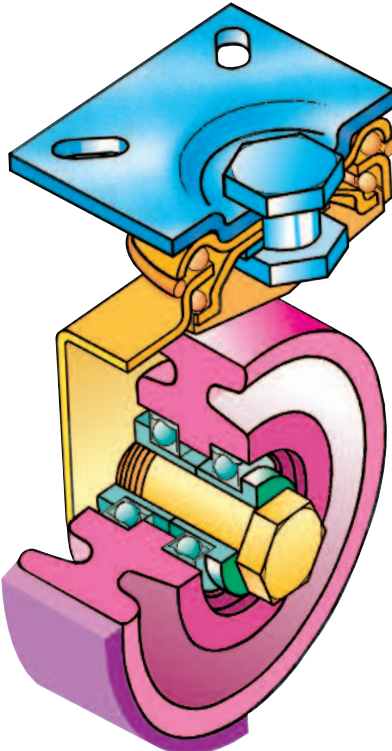

## HOW TO SELECT THE CORRECT CASTER AND WHEEL

Darcor offers you a wide variety of caster types and wheel options – and for good reason. Choosing the correct caster for the job and the work environment dramatically increases the life and performance of the caster – as well as enhancing its ergonomic benefits.

Here's how to select the perfect Darcor caster for your needs.

### LOAD CAPACITY

This is your most important criterion for caster choice. In general, each caster should have the capacity to support one-third of the total load weight. That is because overloading, uneven floors and/or uneven load distribution may place a heavier burden on one or more casters.

To determine the required caster load capacity add the weight of the load and the weight of the cart, then divide by three.

### MAXIMUM MOBILITY

The larger the wheel size (and swivel radius), the greater the mobility. The type of bearing selected will also further improve mobility and reduce rolling resistance.

Darcor's Neoprene, Super Roll Neoprene, Solid Elastomer, and Polyurethane offer maximum mobility in any application they are required for. Your choice should be dictated by conditions in the work environment.

### TREAD MATERIALS AND CASTER TYPES

**Floor Conditions** – Check for rough or uneven surfaces – joints, grates, potholes – oil, grease or chemicals, and note any carpeted areas.

Darcor Neoprene (D & SR) wheels are recommended for all types of floor conditions up to a load capacity of 600 lbs. per caster. For moderate to heavy loads, our Solid Elastomer (SE)<sup>™</sup> wheels are an excellent choice. And for the heaviest loads, choose Polyurethane or Steel wheels.

**Environmental Conditions** - Check for dust, humidity and temperature extremes. Are the floors littered with debris or metal scraps? Darcor Cart Washable Casters are ideal in areas with sprays or wash down requirements. The sealed swivels and rust-inhibiting finish add extra life. Sealed swivels are also a good idea where there is grinding action, lint or dust. They are also quiet – a consideration in hospitals.

### APPLICATION CONSIDERATIONS

Check the speed of your operation. Are you using tow-line vehicles or Automatic Guided Vehicles (AGVs)? Most casters are rated for "walking speed". Higher speed applications decrease their load capacity and can increase heat build-up.

Darcor Solid Elastomer (SE)<sup>™</sup> wheels are a perfect "high speed" choice. In continuous use, they don't build up heat, are easy to manoeuvre with less effort and, because of their exceptionally low rolling resistance, actually extend the "in-use" time for battery powered vehicles.

## TABLE OF CONTENTS

WHEEL MATERIALS .....	1
ACCESSORIES.....	3
BEARINGS AND AXLES.....	4
DARCOR STATEMENT .....	5
OPTIONAL FITTINGS.....	6
STANDARD AND OPTIONAL TOP PLATES .....	8
TUBING & PIPE SIZES.....	9
OFFICE CHAIR CASTERS.....	10
20 SERIES.....	12
30 SERIES.....	14
60 SERIES.....	16
70 SERIES .....	18
400 SERIES .....	20
KINGPINLESS SERIES.....	22
800 SERIES .....	24
700 SERIES.....	26
900 SERIES .....	27
5000 SERIES.....	28
5200 SERIES.....	29
V-GROOVE CASTERS.....	30
SPRING LOADED CASTERS .....	31
GATE SPRING LOADED CASTERS .....	32
LIFT TRUCK APPLICATIONS .....	33
CARTWASHABLE <sup>™</sup> CASTERS .....	34
SPECIAL APPLICATION CASTERS.....	36
MEDICAL APPLICATIONS .....	37
THE MEDIC <sup>™</sup> SERIES.....	38
HOSPITAL BED CASTERS.....	39
NEOPRENE WHEELS .....	40
SOLID ELASTOMER WHEELS .....	42
URETHANE WHEELS.....	44
SEMI-STEEL WHEELS .....	46
RUBBER WHEELS .....	47
GLOSSARY OF TERMS .....	48
CORPORATE INFORMATION.....	49



# ergonomic casters

ISO 9001

REGISTERED

## TOUGH...

Tough conditions are a way of life for Darcor Solid Elastomer 'SE', Neoprene 'D' and 'SR' Super Roll Wheels and Casters. These exceptional casters are designed to survive the harshest environments and operating conditions. They have proved their worth in thousands of miles of use, over years of service in applications worldwide. Darcor wheels stay in shape, protect floors and always swivel and roll freely. They can greatly reduce the risk of back strain.

## SMOOTH...

Our sealed precision ball bearings and highly resilient, durable tread materials provide quiet, smooth mobility with very long life. It takes so little force to move an 'SE' wheel that one person can easily manoeuvre a 2650lbs load. The silent and smooth rolling 'D' and 'SR' wheels have an extraordinary ability to roll over obstacles and floor debris (glass, metal cuttings, plastic resin pellets) without risk of stopping, arring the cart or embedding in the tread. Darcor Solutions are the perfect problem solvers.



DARCOR CASTERS ARE ENGINEERED  
AND MANUFACTURED TO STRINGENT  
STANDARDS FOR STRENGTH,  
RELIABILITY AND EXTENDED LIFE.

[www.darcor.com](http://www.darcor.com)

**D**

**NEOPRENE  
TREAD SYMBOL "D"  
DUROMETER - SHORE 62 A**

Superior for all floor surfaces and ergonomically designed for excellent mobility and resistance to wear. These quiet and easy rolling wheels are very shock absorbing, non-marking and will reject floor debris, roll over screws, metal or glass fragments, resin pellets and are non-staining. Precision ball bearings are standard with all Neoprene wheels..

**SR**

**SUPER ROLL NEOPRENE  
TREAD SYMBOL "SR"  
DUROMETER - SHORE 62 A**

These wheels offer the same high quality as "D" wheels but with a low profile tread for easier swivelling and mobility.

**SE™**

**SOLID ELASTOMER  
TREAD SYMBOL "SE"™  
DUROMETER - SHORE 55 D**

The solid Elastomer Wheel has set a new standard of performance for all applications where exceptional mobility is required. Ergonomically designed for medium loads (300 to 1800 pounds per wheel) the "SE"™ wheel is recommended for continuous use and "TOW LINES". It is also tolerant of a wide range of chemicals and is quiet, durable, shock-absorbing. For the ultimate mobility precision "P" bearings are recommended. The broad temperature range encourages use in freezers where ordinary wheels will seize and become immovable. The "SE"™ wheel is a real "BACK SAVER"

THE TERM 'SE' IS A REGISTERED TRADEMARK OF DARCOR LIMITED.

**SX**

**SOLID ELASTOMER EXTRA WEIGHT  
TREAD SYMBOL "SX"  
DUROMETER - SHORE 63 "D"**

Very similar application and temperature suitability properties to SE wheels. However, the SX will withstand a 20% higher load and offers even greater mobility, due to reduced swivelling and rolling forces for even the most demanding applications.

## WHEEL MATERIALS

**LE**

**LOW EFFORT URETHANE TREAD SYMBOL "LE" DUROMETER - SHORE 80 A**  
A custom-designed problem solver that will outperform conventional urethanes, the LE is highly resistant to chemicals, long lasting and will provide a smooth ride. The resiliency of this material makes it suitable for any floor surface.

**U**

**POLYURETHANE TREAD SYMBOL "U" DUROMETER -SHORE 95 A**  
Recommended for heavy loads and rough floors. Shock-absorbing. When fitted with tapered bearings, improves life and mobility.

**H**

**HARD RUBBER TREAD SYMBOL "H" DUROMETER 78 "D"**  
Extremely tough, hard synthetic rubber material. Good for smooth, clean floors.

**CV**

**V-GROOVE TREAD SYMBOL "CV" CAST IRON**  
Economic handling of heavy loads. Adaptable (Will roll on Track and Floor). Free rolling on sediment covered floors as the Angle Track is self cleaning.

**CI**

**SEMI-STEEL TREAD SYMBOL "CI" CAST IRON**  
Semi-steel castings are good for heavy-duty, smooth, clean floor applications. All wheels are crowned to prevent floor damage. Good for high temperature applications.

## WHEEL SELECTION GUIDE

WHEEL MATERIAL	F L O O R S U R F A C E								
	CARPET	LINOLEUM	WOOD	QUARRY TILE	CEMENT	ASPHALT	TERRAZZO	STEEL	ROUGH AND UNEVEN FLOORS
"D" NEOPRENE	X	X	X	X	X	X	X	X	X
"SR" SUPER ROLL NEOPRENE	X	X	X	X	X	X	X	X	X
"SE"™ SOLID ELASTOMER	X	X	X		X		X	X	
"SX" SE EXTRA WEIGHT	X	X	X		X		X	X	
"U" POLYURETHANE		X	X	X	X	X	X	X	X
"CI" SEMI - STEEL					X			X	
"H" HARD RUBBER	X				X			X	
"LE" LOW EFFORT URETHANE	X	X	X	X	X	X	X	X	X

WHEEL MATERIAL	O P E R A T I N G C O N D I T I O N S							
	TEMPERATURE RANGE	MOBILITY	DURABILITY	FLOOR PROTECTION	CHEMICAL TOLERANCE	GLASS OR METAL CHIPS	WATER	STEAM
"D" NEOPRENE	-20 TO+300°F	EXCELLENT	EXCELLENT	EXCELLENT	EXCELLENT	EXCELLENT	EXCELLENT	EXCELLENT
"SR" SUPER ROLL NEOPRENE	-20 TO+300°F	EXCELLENT	EXCELLENT	EXCELLENT	EXCELLENT	EXCELLENT	EXCELLENT	EXCELLENT
"SE"™ SOLID ELASTOMER	-60 TO+230° F	EXCELLENT	EXCELLENT	EXCELLENT	EXCELLENT	FAIR	EXCELLENT	POOR
"SX" SE EXTRA WEIGHT	-60 TO+230° F	EXCELLENT	EXCELLENT	EXCELLENT	EXCELLENT	FAIR	EXCELLENT	POOR
"U" POLYURETHANE	-40 TO+175°F	EXCELLENT	EXCELLENT	VERY GOOD	VERY GOOD	GOOD	GOOD	POOR
"CI" SEMI - STEEL	-40 TO+500°F	EXCELLENT	GOOD	POOR	GOOD	GOOD	POOR	POOR
"H" HARD RUBBER	-40 TO+110°F	FAIR	FAIR	FAIR	GOOD	POOR	GOOD	FAIR
"LE" LOW EFFORT URETHANE	-40 TO+175°F	EXCELLENT	EXCELLENT	EXCELLENT	VERY GOOD	GOOD	GOOD	POOR

## BREAKS - SWIVEL LOCKS - SWIVEL SEALS - THREAD GUARDS



12-24B-XD

**20 SERIES**

Side brake.  
Hardened spring.  
Steel brake pad for optimum  
braking on light loads.



OU125-BC5B2-XSR

**HOSPITAL BED BRAKE**

Locks swivel and wheel.  
Easy access lever can be en-  
gaged from any position.



16-65B-XD

**60-70 SERIES  
PIT BULL BRAKE**

Specially designed metal pad riv-  
eted to the brake spring for use  
with Neoprene wheels.



6-908B-TU

**700 - 900 SERIES  
DISC BRAKE**

Automotive brake pad material  
offers superior grip for heavy  
loads.



SWIVEL SEAL

**SWIVEL SEALS  
OPTIONAL 60-70 SERIES  
STANDARD 400-800 SERIES.**

Protects swivel from dirt, mois-  
ture and foreign material.

**CENTRAL LOCKING SYSTEM**

Available on twin-wheel  
M5 & M6 series.  
3 positions - free swivel, swivel  
lock and total lock.



TWI-CL1006

**60-70 SERIES**

Wheel brake rubber pad  
riveted to spring steel  
engages against face of wheel.



31-75B-PSE

**400-800 SERIES**

Cam action brake and swivel  
lock. Thick spring steel pad  
grips both the wheel and  
swivel.

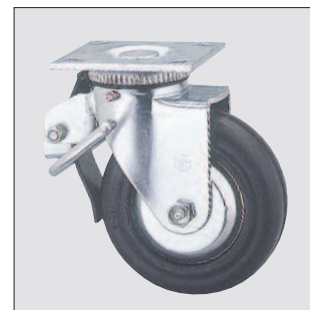

31-406B-TD

**SWIVEL LOCKS**

Available from 40 series up.  
Foot operated for easy  
activation.

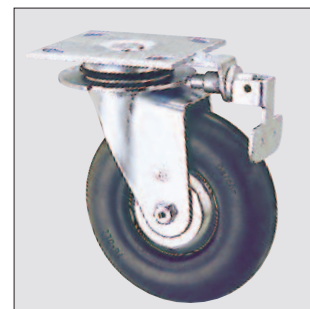

31-76F-XD

**THREAD GUARDS**

Standard on carpet masters  
through 400 series wheels.  
Protects against thread wrap  
up in axles and bearings.



THREAD GUARD

## BEARINGS



**PRECISION SEALED  
BALL BEARING  
DESIGNATION "P"**

Offers least rolling resistance.  
Never requires lubrication.  
For medium loads, side thrust  
and high speeds.  
\*blue dot on yoke

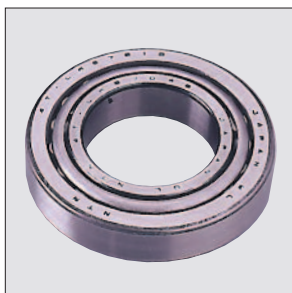

**TAPERED  
ROLLER BEARING  
DESIGNATION "Y"**

For heavy loads, side thrust and  
high speeds.



**DELRIN™ BEARING  
DESIGNATION "M"**

A strong bearing material that  
resists corrosion.  
Ideal in wet applications.  
Requires lubrication.

\* DELRIN is a registered trademark of the DuPont Co.

**ROLLER BEARING.  
SPLIT SLEEVE OR DRAWN  
CUP  
DESIGNATION "T"**

Rollers turn on a hardened steel  
spanner bushing.  
\*green dot on yoke

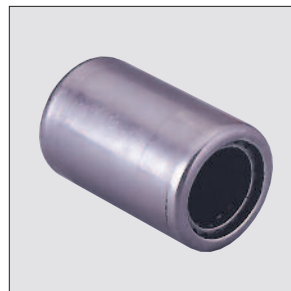

**SLEEVE BEARING  
(BUSHING)**

Case hardened steel.  
An inexpensive bearing for  
lighter loads.



## AXLES



**PLAIN AXLE**

Standard in 20 series and all  
casters with sealed precision  
bearings. Also heavy duty  
series casters with grease  
fittings in wheel.

**SELF TAPPING ALLEN  
HEAD AXLE**

Used with E2 and Carpet  
Master. Eliminates unsightly  
nut. Prevents wear on shoes  
and nylon runs.



**CROSS DRILLED AXLE**

Standard on 60 and 70 series  
casters. Axle is drilled through  
center. Allows grease to flow  
into the bearing.

**GREASE FITTING IN AXLE**

Standard on 400 series  
optional 60 and 70 series.  
Cross drilled axle with  
zerk fitting in end.  
Fits standard grease guns.





## DARCOR IS THE STANDARD BY WHICH ALL OTHER CASTERS ARE MEASURED

That is a bold statement – and one we stand behind totally. Just ask our customers. Talk to the many specialty manufacturers who have come to us for unique solutions to their caster needs. Speak with the international names in business and industry who have chosen Darcor casters to make their operations run more smoothly, more efficiently. • What each of them will tell you is this: Darcor casters set the quality standards for the industry; Darcor is unmatched in its ability to deliver the perfect caster for specific applications. • We are aware our reputation rests on every caster we produce. That is why we maintain complete control over every aspect of their production in our own multifaceted manufacturing plant, featuring state-of-the-art in-house facilities and an expert, dedicated workforce. • In this catalogue, you will find a complete range of the casters and wheels most frequently used by organizations like yours. You will also find something else: Casters and wheels which represent breakthrough advances that will markedly improve the function of your operations over the long term. • Research and development is one of our strengths. It allows us to actually anticipate the need for new types of casters in today's rapidly evolving manufacturing environment. We are able to respond with uniquely designed products that blend ergonomic principles and advanced materials to

improve bottom-line results and workplace conditions.

• As a result, we have had more than our share of innovations so revolutionary they have redefined the function of casters in the workplace. Among those revolutionary innovations are the Neoprene (D) wheel and the Solid Elastomer SE™ wheel. Check the specifications for these remarkable wheels and you will be amazed at their versatility and practicality. • When you choose a Darcor caster, you can rest easy, secure in the knowledge you have chosen the best. • We design to achieve a perfect match between need and caster. We engineer for strength, reliability and extended life. And we manufacture our casters under rigid controls that guarantee maximum long-life performance. • To ensure their integrity, we subject our casters to destruction tests under unbelievably hostile conditions. • So, while Darcor casters may have a higher value proposition, they are actually the lowest-cost casters you can buy – because they are made to last. • Remember our promise: Anything that moves will move better on a Darcor Caster. It's a promise you can profit from.

## STEMS AND OPTIONAL FITTINGS

MODEL # PREFIX	DIAMETER X LENGTH	AVAILABLE ON CASTER SERIES					
		E2	53	20	30	60	70
CS125	1-1/4 square socket					60	
CS150	1-1/2 square socket					60	
CS150	1-5/8 round socket					60	
JA	7/16" x 1-7/8"	E2	53	20			
LA	5/16" x 1" NC	E2	53	20			
LB	5/16" x 1-1/2" NC	E2	53	20			
LD	3-8" x 3/4" NC		53	20			
LE	3/8" x 1-1/4" NC		53	20			
LG	1/2" x 5/8" NC		53	20	30	60	
LH	1/2" x 1-1/2" NC		53	20	30	60	70
LK	1/2" x 2" NC		53	20	30	60	
LN	5/8 x 2" NC		53	20	30	60	70
LR	3/4" x 2" NC		53	20	30	60	70
OA	3/8" x 1"	E2	53	20			
OB	7/16" x 13/16"	E2	53	20			
OC	7/16" x 1-1/4"	E2	53	20			
OD	7/16" x 1-3/4"	E2	53	20			
OE	7/16" x 2"	E2	53	20			
OJ	7/16" x 1-1/2"				30	60	
OH	1/2" x 1-1/8"		53	20	30	60	
OM	9/16" x 4-1/2"		53	20			
OU	5/8" x 1-5/8"		53	20	30	60	70
OY	3/4" x 1-5/8"		53	20	30	60	70
OCC	13/16" x 2"				30	60	70
OEE	0.862" x 1-1/2"		53	20	30	60	
OGG	7/8" x 1-7/8"		53	20			
OHH	7/8" x 2"				30	60	70
OKK	1" x 1-5/8"		53	20	30	60	70
OKW	3/4" x 1-5/8" w/ .188 key				30	60	70
OXX	1.480 x 2-1/2					60	70
PBE	1/2" Pipe bushing		53	20	30	60	
PBF	3/4" Pipe bushing		53	20	30	60	70
PBG	1" Pipe bushing			20	30	60	70
PBH	1-1/4" Pipe bushing				30	60	
PCE	1/2" Pipe cap		53	20	30	60	
PCF	3/4" Pipe cap		53	20	30	60	70
PCG	1" Pipe cap				30	60	70
PCH	1-1/4" Pipe cap				30	60	
SA	Square 3/4" x 2"		53	20	30	60	
SB	Square 7/8" x 2-1/2"				30	60	70
SC	Square 7/8" x 2-1/2"			20	30	60	70

# STEMS AND OPTIONAL FITTINGS

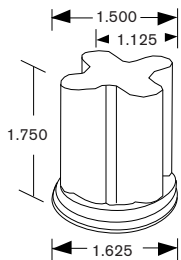

**CS 158 SOCKET FITS**  
 1-5/8" 16 GAUGE  
 ROUND TUBING USE  
 WITH "OU" STEM  
 5/8" x 1-5/8"

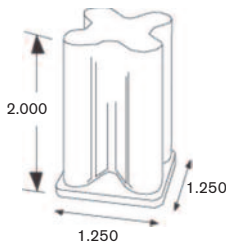

**CS 125 SOCKET**  
 FITS 1-1/4"  
 14 GAUGE SQUARE  
 TUBING SIZE WITH  
 "OU" STEM  
 5/8" x 1-5/8"

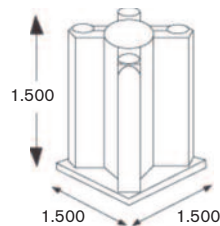

**CS 150 SOCKET FITS**  
 1-1/2" 18 GAUGE  
 SQUARE TUBING  
 USE WITH "OU" STEM  
 5/8" X 1-5/8"

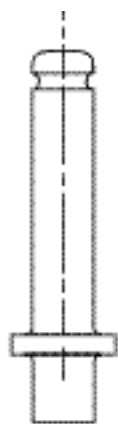

**O SERIES**



**JA STEM**

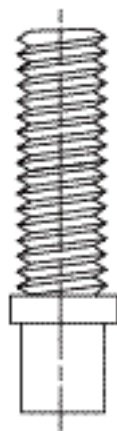

**L SERIES**

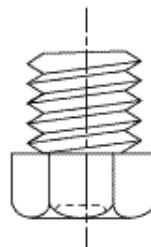

**PIPE BUSHING  
 PB STEM**



**PIPE CAP  
 PC STEM**

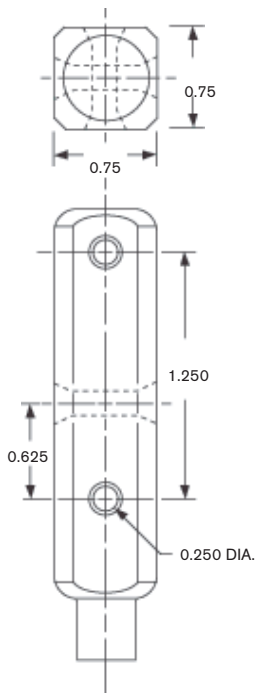

**SA STEM**

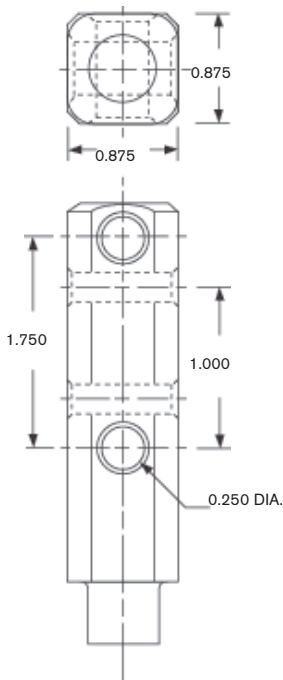

**SB STEM**

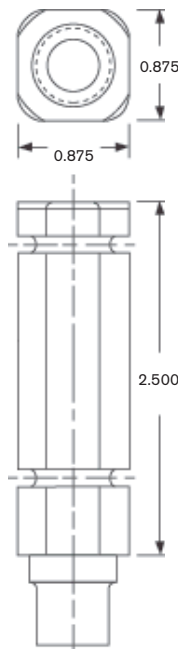

**SC STEM**

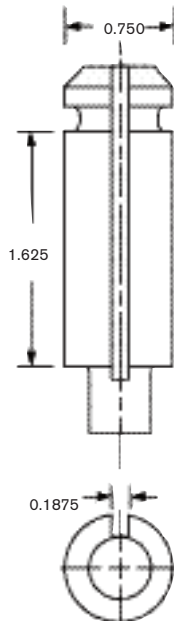

**OKW STEM**

## TOP PLATES - STANDARD AND OPTIONAL

Over the years, Darcor has manufactured many different sizes of top plates to eliminate problems when changing casters. These top plates are shown as options. Darcor can manufacture other top plates as required, provided the bolt hole centers do not interfere with the swivel raceway. Their cost is based on size and quantity.

TOP PLATE NUMBER	OVERALL SIZE		BOLT HOLE CENTERS (SEE DIAGRAMS)				MOUNTING BOLT SIZE	STANDARD ON SERIES	* OPTIONAL ON SERIES
	WIDTH	LENGTH	WIDTH	LENGTH	WIDTH	LENGTH			
	W x L		A - B		C - D		E		
3 (Swivel only)	1-3/8 x 1-7/8		13/16 x 1-3/8					3/16	E2
3	4 x 4		3 x 3					3/8 - 9/16	30-60-70-400
4 (Swivel only)	1-1/4 x 2-3/8		13/16 x 1-7/8					3/16	53-20
4	4 x 7		3 x 6					3/8	400
5 (Swivel only)	1-7/8 x 2-5/8		1-1/4 x 2					1/4	53-20
6 (Slotted)	5 x 7		3-3/8 x 5-1/4		4-1/8 x 6-1/8			1/2	700-900 400-800
7 (Swivel only)	2 x 2-1/8		1-1/2 x 1-1/2					1/4	53-20
8 (Slotted)	4-1/2 x 6-1/4		2-7/16 x 4-15/16		3-3/8 x 5-1/4			1/2	800 400
9	3-3/8 x 4-3/8		2-3/8 x 3-3/8					3/8 - 9/16	30-60-70-400
11 Swivel only	1-3/4 x 3		1 x 2-1/4					1/4	53-20
12 (Swivel-elongated holes)	2-1/2 x 3-5/8		1-3/4 x 2-3/4		x 2-7/8		3	5/16	20 53
12 (Rigid-elongated holes)	2-3/4 x 4		1-3/4 x 2-3/4		x 2-7/8		3	5/16	20
14	4 x 5		3 x 4					3/8	70-400
16 (Swivel-elongated holes)	2-1/2 x 3-5/8		1-3/4 x 2-3/4		x 2-7/8		3	5/16	30-60 70 Swivel & Rigid
16 (Rigid-elongated holes)	2-7/8 x 4-1/8		1-3/4 x 2-3/4		x 2-7/8		3	5/16	30-60
19 (Swivel only)	3-3/8 x 4-3/8		2-3/8 x 3-3/8					3/8	70 Swivel
22	3-7/8 x 6-1/4		2-7/16 x 4-7/8					3/8	400
31 (Slotted)	4 x 4-1/2		2-5/8 x 3		3 x 3-5/8			3/8	70-400 30-60
5-5000	6 x 10		4-3/4 x 8-3/4					1/2	5000
5-5200	6 x 12		4-1/2 x 10-1/2					1/2	5200
IS 2 (Slotted)	85mm x 100mm		45mm x 75mm		60mm x 80mm			9mm	30-60-70
IS 3 (Elongated)	110mm x 140mm		73mm x 105mm		80mm x		87mm	11mm	30-60-70-400

\* All top plates available as options on other series are subject to special pricing.

## DIMENSIONS

### IS ELONGATED

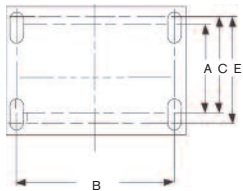

### OVERALL



### IS SLOTTED

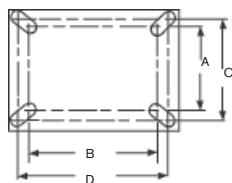

### BOLT HOLE CENTERS

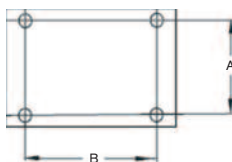

### SLOTTED

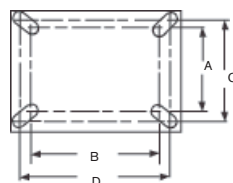

### ELONGATED

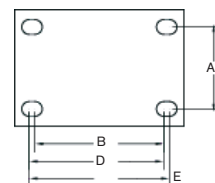



## TUBING AND PIPE SIZES

Due to the large quantity of tubing sizes available, we have endeavoured over the years to manufacture stems to fit most standard sizes of tubing. We do not feel that expanding stems are the proper solution to these problems, as they have a tendency to wear and become loose. Our stems are equipped with a grip ring made from hardened spring steel to eliminate wear. Most of these can be installed at no extra charge where they apply to the series of caster. Please check optional fitting pages, for available sizes.

### STANDARD IRON PIPE SIZES:

TUBING SIZE	"0" STEM SIZE REQUIRED
1" 16 GA Square Tubing	7/8 x 2
1" 16 GA Round Tubing	.862 x 1-1/2
1" 18 GA Round Tubing	.895 x 1-1/2
1-5/8" 16 GA Round Tubing	1.480 x 2-1/2
1-5/8" 16 GA Round Tubing	CS 158 Socket (5/8 x 1-5/8 Stem)
1-1/4" 14 GA Square Tubing	CS 125 Socket (5/8 x 1-5/8 Stem)
1-1/2" 18 GA Square Tubing	CS 150 Socket (5/8 x 1-5/8 Stem)

PIPE SIZE	INSIDE DIAMETER (DECIMAL)	INSIDE DIAMETER (FRACTION)	OUTSIDE DIAMETER
3/8"	.493	31/64"	.675
1/2"	.622	5/8"	.840
3/4"	.824	53/64"	1.050
1"	1.049	1-3/64"	1.315
1-1/4"	1.380	1-3/8"	1.660
1-1/2"	1.610	1-39/64"	1.900

## CASTER MOUNTING CONFIGURATIONS

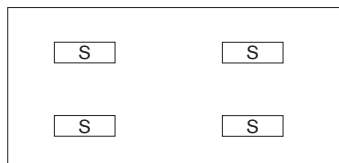

**Four Swivel**

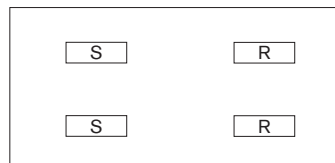

**Two Swivel      Two Rigid**

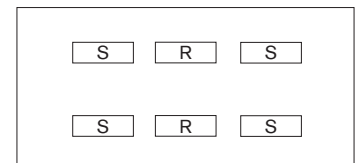

**Four Swivel      Two Rigid**

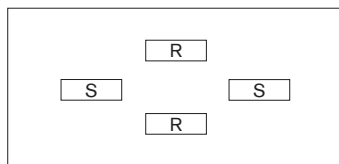

**Diamond Mounting**

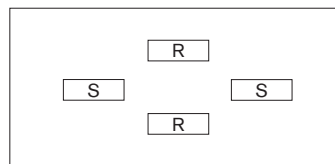

**Tilt Mount**

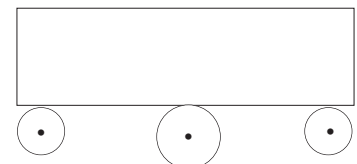

**Tilt Mount Side View**

# OFFICE CHAIR CASTERS

Office Chair Casters by Darcor have earned a distinguished reputation for quality, based on years of consistently high performance and durability. Their product stature is attributed to Darcor's dedication to meticulous research, design, engineering and testing. Widely used on office chairs, they are equally useful for many institutional applications including IV poles, overbed tables, nightstands and many other uses.

Darcor's innovative designs not only reduce wear and tear on the mechanism of chairs but increase the user's physical efficiency and comfort by reducing the strain of moving the chair during daily chores at workstations. Darcor's designs eliminate the frustrating experience of shoving and ploughing office chairs through carpets and over warped plastic mats.

The Carpet Master™ for carpeted floors, and the Eternity II for tile and linoleum floors - are synonymous with comfort. They have the qualities desired in a superior product, such as reliability, durability and unparalleled ease of movement. Both the Carpet Master™ and Eternity II incorporate the legendary Darcor double ball bearing swivel design, with two ball bearing races of equal diameter. This ingenious design eliminates any possibility of binding, sticking, or sliding.

## THE CARPET MASTER



OC-53-XD

The Carpet Master rolls and swivels effortlessly, eliminating the need for unsightly and hazardous plastic mats. The silent, donut neoprene wheel with its soft resilient texture, rolls smoothly and quietly on all floor surfaces from carpet to quarry tile. The large swivel off-set and soft wheel reduces the stress on carpet fibers thus greatly extending carpet life. Carpet Master's are available in standard chrome and black matte finish. Also available with bright brass and brushed brass finish.

### FEATURES

- 5/16" Axle
- 7/16" Rivet
- Double row ball bearing swivel, both raceways equal diameter. Ball bearings standard in wheel.
- Specially designed removable axle eliminates unsightly nut
- All swivel parts are case hardened
- Thread guards standard

## ETERNITY II



OC-E2-XD

The Eternity II is recommended for all types of hard floors. The neoprene wheel will not mark or stain tile and has a remarkable inter-floor capability. Darcor casters are available with optional fittings, including top plates, stems and sockets. Eternity II has a standard chrome or black matte finish and is also available with a bright brass finish.

### FEATURES

- 5/16" Axle
- 11/32" Rivet
- Double row ball bearing swivel, both raceways equal diameter. Ball bearings standard in wheel.
- Specially designed removable axle eliminates unsightly nut
- All swivel parts are case hardened

OPTIONAL TOP PLATES AND STEMS ARE AVAILABLE.

## OFFICE CHAIR CASTERS

## THE CARPET MASTER

WHEEL DIAMETER	TREAD WIDTH	LOAD CAP. /LBS	BEARING TYPE	FINISH	MODEL NUMBER	SWIVEL RADIUS	OVERALL HEIGHT
<b>NEOPRENE</b>							
3"	1"	100	BALL	CHROME	53-XD	3-1/8"	3-15/16"
3"	1"	100	BALL	BLACK MATTE	BM53-XD	3-1/8"	3-15/16"
3"	1"	100	BALL	BRIGHT BRASS	BB53-XD	3-1/8"	3-15/16"
3"	1"	100	BALL	ANTIQUÉ BRONZE	AB53-XD	3-1/8"	3-15/16"
<b>HARD RUBBER</b>							
3"	1"	125	BALL	CHROME	53-XH	3-1/8"	3-15/16"
3"	1"	125	BALL	BLACK MATTE	BM53-XH	3-1/8"	3-15/16"
3"	1"	125	BALL	BRIGHT BRASS	BB53-XH	3-1/8"	3-15/16"
3"	1"	125	BALL	ANTIQUÉ BRONZE	AB53-XH	3-1/8"	3-15/16"

## ETERNITY II

WHEEL DIAMETER	TREAD WIDTH	LOAD CAP. /LBS	BEARING TYPE	FINISH	MODEL NUMBER	SWIVEL RADIUS	OVERALL HEIGHT
<b>NEOPRENE</b>							
2"	1"	75	BALL	CHROME	E2-XD	2"	2-3/4"
2"	1"	75	SLEEVE	CHROME	E2-D	2"	2-3/4"
2"	1"	75	BALL	BLACK MATTE	BME2-XD	2"	2-3/4"
2"	1"	75	SLEEVE	BLACK MATTE	BME2-D	2"	2-3/4"
2"	1"	75	BALL	BRIGHT BRASS	BBE2-XD	2"	2-3/4"
2"	1"	75	SLEEVE	BRIGHT BRASS	BBE2-D	2"	2-3/4"
<b>HARD RUBBER</b>							
2"	1"	75	BALL	CHROME	E2-XH	2"	2-3/4"
2"	1"	75	SLEEVE	CHROME	E2-H	2"	2-3/4"
2"	1"	75	BALL	BLACK MATTE	BME2-XH	2"	2-3/4"
2"	1"	75	SLEEVE	BLACK MATTE	BME2-H	2"	2-3/4"
2"	1"	75	BALL	BRIGHT BRASS	BBE2-XH	2"	2-3/4"
2"	1"	75	SLEEVE	BRIGHT BRASS	BBE2-H	2"	2-3/4"



12-24-XD

**FEATURES**

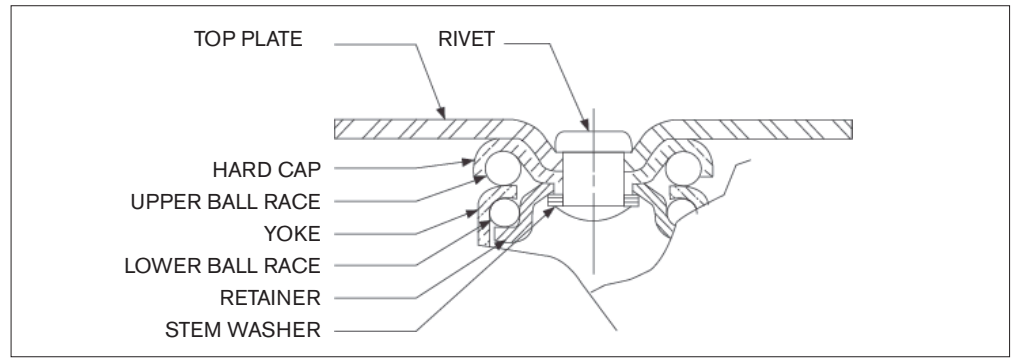

- 5/16" Axle
- 7/16" Rivet
- Double row ball bearing swivel. Both raceways equal diameter.
- Bright zinc finish
- All swivel parts case hardened to Rockwell 62C
- Thread guards standard on sizes larger than 2"



12-24R-XD

**OPTIONS**

- Brakes available on 3", 4" and 5" models. Add letter "B".

**INSTALLATIONS**



12-24B-XD

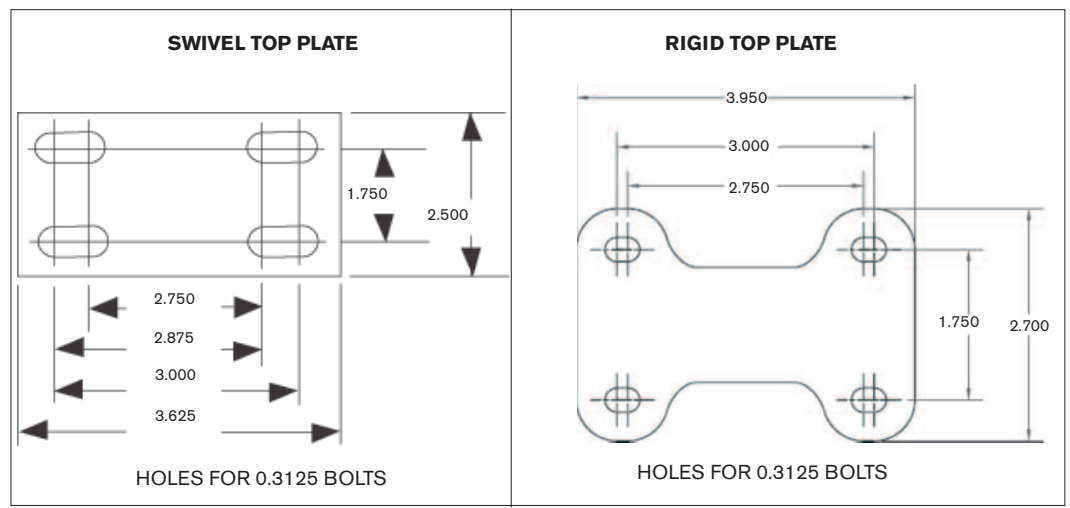

**NO. 12 TOP PLATE (STANDARD ON 20 SERIES)**

OPTIONAL TOP PLATES AND STEMS AVAILABLE



WHEEL DIAMETER	TREAD WIDTH	LOAD CAP./LBS	BEARING TYPE	SWIVEL MODEL	RIGID MODEL	SWIVEL RADIUS	OVERALL HEIGHT
<b>NEOPRENE</b>							
2"	1"	125	BALL	12-22-XD	12-22R-XD	2"	3-1/8"
2"	1"	75	SLEEVE	12-22-D	12-22R-D	2"	3-1/8"
3"	1"	125	BALL	12-23-XD	12-23R-XD	3"	4-1/4"
3"	1"	75	SLEEVE	12-23-D	12-23R-D	3"	4-1/4"
4"	1"	125	BALL	12-24-XD	12-24R-XD	3-3/8"	5-1/4"
4"	1"	75	SLEEVE	12-24-D	12-24R-D	3-3/16"	5-1/4"
5"	1"	125	BALL	12-25-XD	12-25R-XD	3-7/8"	6-1/4"
5"	1"	75	SLEEVE	12-25-D	12-25R-D	3-7/8"	6-1/4"
<b>NEOPRENE SUPER ROLL</b>							
2-1/2"	1"	125	BALL	12-22.5-XSR	12-22.5R-XSR	2-1/8"	3-5/8"
2-1/2"	1"	75	SLEEVE	12-22.5-SR	12-22.5R-SR	2-1/8"	3-5/8"
<b>SEMI-STEEL</b>							
2"	1"	100	SLEEVE	12-22-CI	12-22R-CI	2"	3-1/8"
2-1/2"	1"	125	SLEEVE	12-22.5-CI	12-22.5R-CI	2-1/8"	3-5/8"
<b>HARD RUBBER</b>							
2"	1"	100	BALL	12-22-XH	12-22R-XH	2"	3-1/8"
2"	1"	100	SLEEVE	12-22-H	12-22R-H	2"	3-1/8"
2-1/2"	1"	125	SLEEVE	12-22.5-H	12-22.5R-H	2-1/8"	3-5/8"
3"	1"	125	SLEEVE	12-23-H	12-23R-H	3"	4-1/4"
4"	1"	125	SLEEVE	12-24-H	12-24R-H	3-3/8"	5-1/4"



16-32-XD



16-32R-XD



16-32.5-XSR



16-32.5R-XSR

**FEATURES**

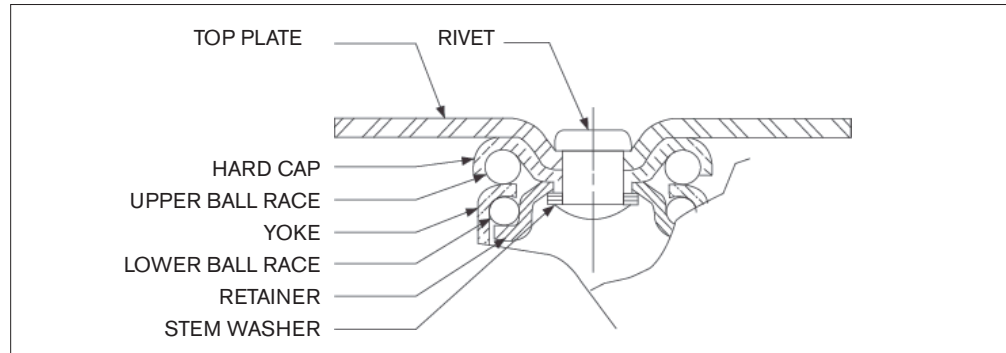

- 5/16" Axle
- 1/2" Rivet
- Double row ball bearing swivel. Both raceways equal diameter
- Bright chrome finish
- All swivel parts case hardened to Rockwell 62C
- Thread guards standard on 2-1/2" wheels

**INSTALLATIONS**

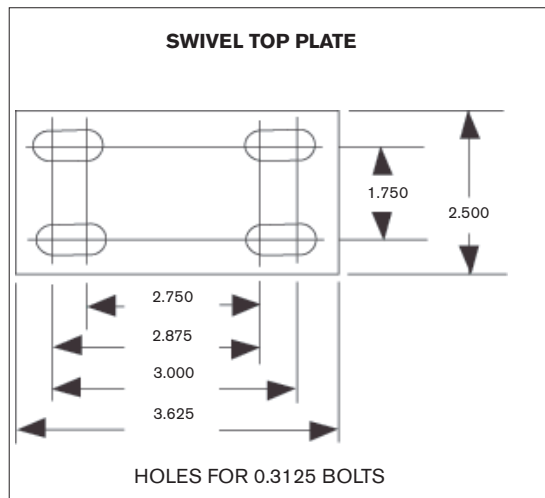

**NO. 16 TOP PLATE**

OPTIONAL TOP PLATES AND STEMS AVAILABLE

OTHER SIZES (3", 4" AND 5") AVAILABLE ON SPECIAL ORDER.

## 30 SERIES - TWIN WHEEL

WHEEL DIA.	TREAD WIDTH	LOAD CAP./LBS	BEARING TYPE	SWIVEL MODEL	RIGID MODEL	SWIVEL RADIUS	OVERALL HEIGHT
<b>NEOPRENE SUPER ROLL</b>							
2"	1"	300	BALL	16-32-XD	16-32R-XD	2-3/8"	3-1/4"
2-1/2"	1"	300	BALL	16-32.5-XSR	16-32.5R-XSR	2-5/8"	3-7/8"
<b>HARD RUBBER</b>							
2"	1"	400	BALL	16-32-XH	16-32R-XH	2-3/8"	3-1/4"
2-1/2"	1"	400	BALL	16-32.5-XH	16-32.5R-XH	2-5/8"	3-7/8"



16-65-XD

**FEATURES**

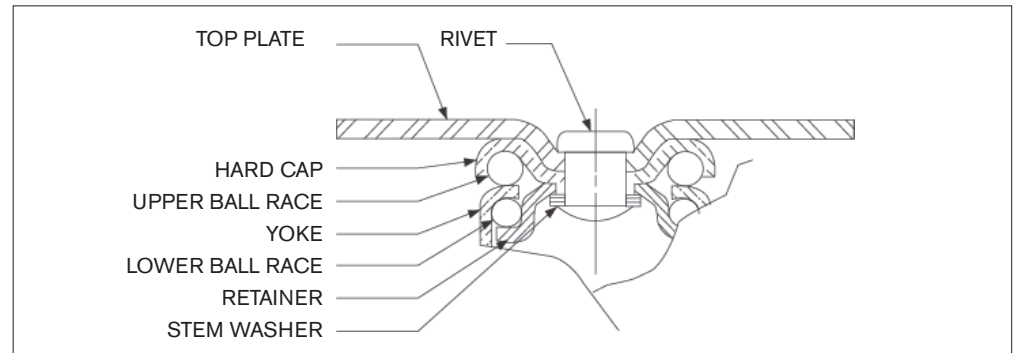

- 3/8" Axle
- 1/2" Rivet
- Double row ball bearing swivel. Both raceways equal diameter
- Bright zinc finish
- All swivel parts case hardened to Rockwell 62C
- Thread guards standard on wheels



16-65R-XD

**OPTIONS**

- Brakes available, 3", 3.5", 4", and 5" models. Add letter "B".
- Four position swivel locks. Add letter "F". Not available on stem casters.
- Brakes and swivel locks cannot be combined on the same caster.
- Swivel seals with zerk in swivel and axle. Add letter "S".
- Zerk in axle only. Add letter "G".

**INSTALLATIONS**



16-65B-XSR

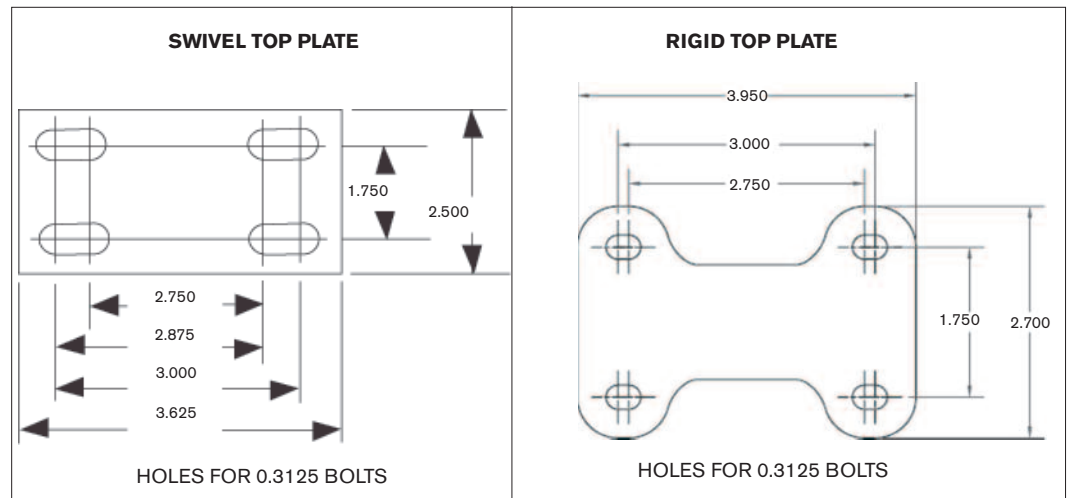

**NO. 16 TOP PLATE (STANDARD ON 60 SERIES)**

OPTIONAL TOP PLATES AND STEMS AVAILABLE



WHEEL DIAMETER	TREAD WIDTH	LOAD CAP./LBS	BEARING TYPE	SWIVEL MODEL	RIGID MODEL	SWIVEL RADIUS	OVERALL HEIGHT
<b>NEOPRENE</b>							
3"	1-3/8"	200	BALL	16-63-XD	16-63R-XD	2-3/4"	4-5/16"
3-1/2"	1-3/8"	200	BALL	16-63.5-XD	16-63.5R-XD	3"	4-3/4"
4"	1-3/8"	225	BALL	16-64-XD	16-64R-XD	3-1/4"	5-5/16"
5"	1-3/8"	250	BALL	16-65-XD	16-65R-XD	4"	6-5/16"
<b>NEOPRENE - SUPER ROLL</b>							
2-1/2"	1-3/8"	200	BALL	16-62.5-XSR	16-62.5R-XSR	2-1/2"	3-13/16"
3-1/2"	1-3/8"	225	BALL	16-63.5-XSR	16-63.5R-XSR	3"	4-3/4"
4"	1-3/8"	275	BALL	16-64-XSR	16-64R-XSR	3-1/4"	5-5/16"
5"	1-3/8"	325	BALL	16-65-XSR	16-65R-XSR	4"	6-5/16"
<b>SOLID ELASTOMER</b>							
2-1/2"	1-1/4"	300	BALL	16-62.5-XSE	16-62.5R-XSE	2-1/2"	3-13/16"
3-1/2"	1-1/4"	350	BALL	16-63.5-XSE	16-63.5R-XSE	3"	4-3/4"
<b>SEMI-STEEL</b>							
2-1/2"	1-1/4"	400	SLEEVE	16-62.5-CI	16-62.5R-CI	2-1/2"	3-13/16"
3"	1-3/8"	400	SLEEVE	16-63-CI	16-63R-CI	2-3/4"	4-5/16"
3-1/2"	1-1/4"	400	SLEEVE	16-63.5-CI	16-63.5R-CI	3"	4-3/4"
4"	1-3/8"	400	SLEEVE	16-64-CI	16-64R-CI	3-1/4"	5-5/16"
5"	1-3/8"	400	SLEEVE	16-65-CI	16-65R-CI	4"	6-5/16"
<b>V-GROOVED</b>							
3"	1-1/4"	300	SLEEVE	16-63-CV	16-63R-CV	2-3/4"	4-5/16"
<b>HARD RUBBER</b>							
3"	1-3/8"	350	SLEEVE	16-63-H	16-63R-H	2-3/4"	4-5/16"
3-1/2"	1-3/8"	375	SLEEVE	16-63.5-H	16-63.5R-H	3"	4-3/4"
4"	1-3/8"	400	SLEEVE	16-64-H	16-64R-H	3-1/4"	5-5/16"
5"	1-3/8"	400	SLEEVE	16-65-H	16-65R-H	4"	6-5/16"

SLEEVE - M - BEARINGS AVAILABLE FOR WET APPLICATIONS.



31-76-XSR



31-76R-XD



31-76B-XD



31-76-PSE

FEATURES

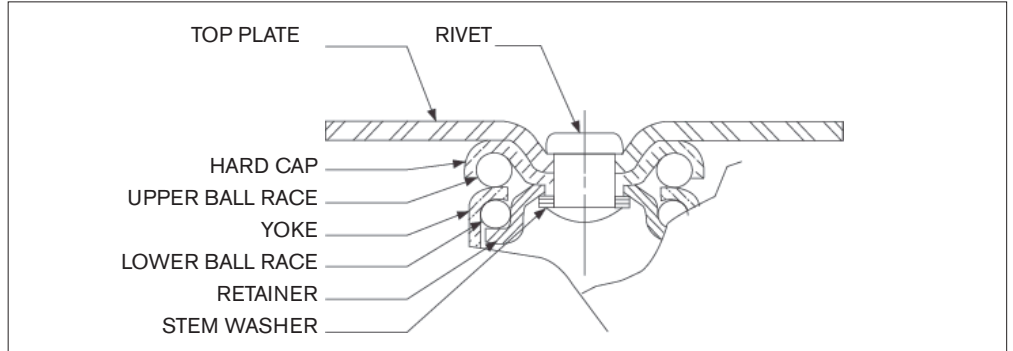

- 3/8" Axle
- 9/16" Rivet.
- Double row ball bearing swivel. Both raceways equal diameter
- Bright zinc finish
- All swivel parts case hardened to Rockwell 62C
- Thread guards standard on wheels

OPTIONS

- Brakes available, on 4", 5", and 6" models. Add letter "B"
- Four Position Swivel locks. Add letter "F".
- Swivel seals with zerk in swivel and axle. Add letter "S".
- Zerk in axle only. Add letter "G".

INSTALLATIONS

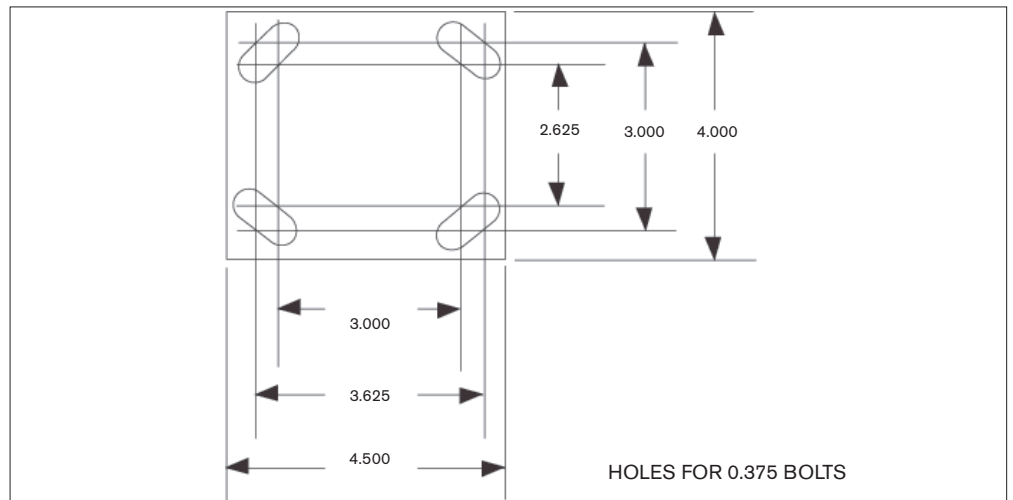

NO. 31 (STANDARD ON 70 SERIES)  
OPTIONAL TOP PLATES AVAILABLE

WHEEL DIAMETER	TREAD WIDTH	LOAD CAP./LBS	BEARING TYPE	SWIVEL MODEL	RIGID MODEL	SWIVEL RADIUS	OVERALL HEIGHT
<b>NEOPRENE</b>							
3"	1-3/8"	225	BALL	31-73-XD	31-73R-XD	3"	4-5/8"
4"	1-3/8"	250	BALL	31-74-XD	31-74R-XD	3-1/2"	5-9/16"
5"	1-3/8"	275	BALL	31-75-XD	31-75R-XD	4"	6-5/8"
6"	1-5/8"	300	BALL	31-76-XD	31-76R-XD	4-7/8"	7-9/16"
<b>NEOPRENE SUPER ROLL</b>							
4"	1-3/8"	300	BALL	31-74-XSR	31-74R-XSR	3-1/2"	5-9/16"
5"	1-3/8"	350	BALL	31-75-XSR	31-75R-XSR	4"	6-5/8"
6"	1-1/2"	400	BALL	31-76-XSR	31-76R-XSR	4-7/8"	7-9/16"
<b>SOLID ELASTOMER</b>							
3"	1-3/8"	500	PRECISION BALL	31-73-PSE	31-73R-PSE	3"	4-5/8"
4"	1-3/8"	600	PRECISION BALL	31-74-PSE	31-74R-PSE	3-1/2"	5-9/16"
5"	1-3/8"	600	PRECISION BALL	31-75-PSE	31-75R-PSE	4"	6-5/8"
6"	1-3/8"	600	PRECISION BALL	31-76-PSE	31-76R-PSE	4-7/8"	7-9/16"
<b>URETHANE</b>							
4"	1-3/8"	600	ROLLER	31-74-TU	31-74R-TU	3-1/2"	5-9/16"
5"	1-3/8"	600	ROLLER	31-75-TU	31-75R-TU	4"	6-5/8"
6"	1-3/8"	600	ROLLER	31-76-TU	31-76R-TU	4-7/8"	7-9/16"
<b>SEMI-STEEL</b>							
3"	1-3/8"	500	SLEEVE	31-73-CI	31-73R-CI	3"	4-5/8"
3"	1-3/8"	500	ROLLER	31-73-TCI	31-73R-TCI	3"	4-5/8"
4"	1-3/8"	600	SLEEVE	31-74-CI	31-74R-CI	3-1/2"	5-9/16"
4"	1-3/8"	600	ROLLER	31-74-TCI	31-74R-TCI	3-1/2"	5-9/16"
5"	1-3/8"	600	SLEEVE	31-75-CI	31-75R-CI	4"	6-5/8"
5"	1-3/8"	600	ROLLER	31-75-TCI	31-75R-TCI	4"	6-5/8"
6"	1-3/8"	600	SLEEVE	31-76-CI	31-76R-CI	4-7/8"	7-9/16"
<b>V-GROOVED</b>							
4"	1-3/8"	500	ROLLER	31-74-TCV	31-74R-TCV	3-1/2"	5-9/16"
5"	1-1/2"	600	ROLLER	31-75-TCV	31-75R-TCV	4"	6-5/8"
<b>HARD RUBBER</b>							
3"	1-3/8"	500	SLEEVE	31-73-H	31-73R-H	3"	4-5/8"
4"	1-3/8"	550	SLEEVE	31-74-H	31-74R-H	3-1/2"	5-9/16"
5"	1-3/8"	600	SLEEVE	31-75-H	31-75R-H	4"	6-5/8"
6"	1-3/8"	600	SLEEVE	31-76-H	31-76R-H	4-7/8"	7-9/16"

SLEEVE - 'M' - BEARINGS AVAILABLE FOR WET APPLICATIONS



31-406-PSE



31-406R-PD



31-406B-TD



31-406F-PSE

FEATURES

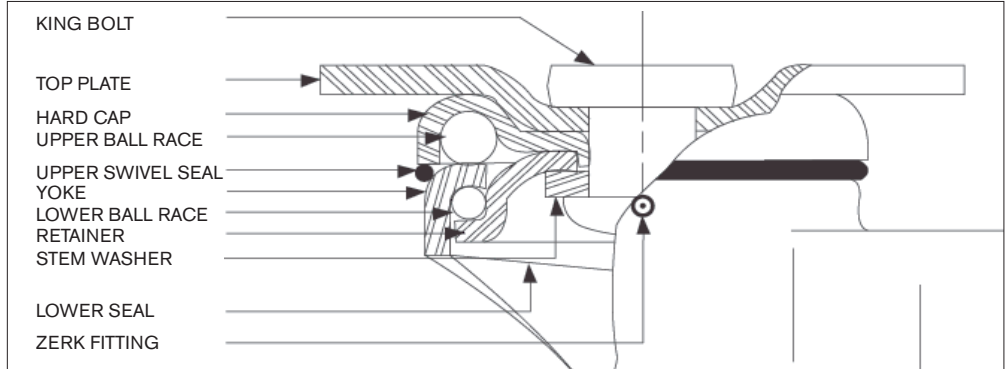

- 1/2" Axle
- 3/4" Rivet
- Double row ball bearing swivel. Both raceways equal diameter
- Standard with swivel seals and grease fittings in swivel and axle
- Bright zinc finish
- All swivel parts case hardened to Rockwell 62C
- Thread guards standard on wheels

OPTIONS

- Brakes, locks wheel and swivel. Available on 4", 5", 6" and 8" models. Add letter "B".
- Four position swivel locks. Add letter "F".
- Brakes and swivel locks cannot be combined on the same caster.

INSTALLATIONS

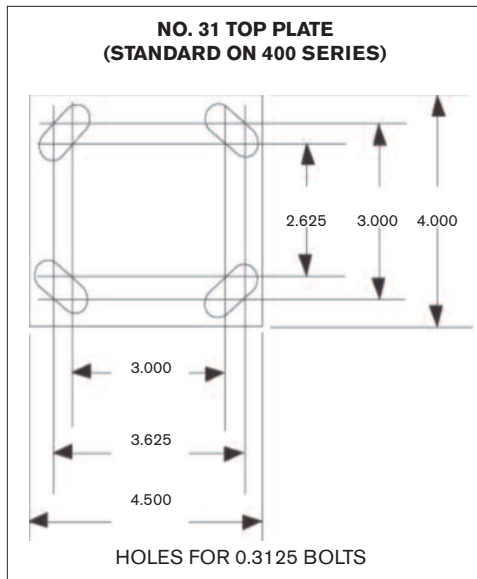

OPTIONAL TOP PLATES

- NO. 4 TOP PLATE
- NO. IS3 TOP PLATE
- NO. 6 TOP PLATE
- NO. 8 TOP PLATE
- NO. 14 TOP PLATE
- NO. 22 TOP PLATE



WHEEL DIAMETER	TREAD WIDTH	LOAD CAP./LBS	BEARING TYPE	SWIVEL MODEL	RIGID MODEL	SWIVEL RADIUS	OVERALL HEIGHT
<b>NEOPRENE</b>							
4"	2"	500	PRECISION BALL	31-404-PD	31-404R-PD	3-5/8"	5-5/8"
5"	2"	550	PRECISION BALL	31-405-PD	31-405R-PD	4-1/4"	6-11/16"
6"	2"	600	PRECISION BALL	31-406-PD	31-406R-PD	4-5/8"	7-11/16"
8"	2"	600	PRECISION BALL	31-408-PD	31-408R-PD	5-3/4"	9-3/4"
<b>SOLID ELASTOMER</b>							
3"	2"	900	PRECISION BALL	31-403-PSE	31-403R-PSE	3-1/4"	4-3/4"
4"	2"	900	PRECISION BALL	31-404-PSE	31-404R-PSE	3-5/8"	5-5/8"
5"	2"	1000	PRECISION BALL	31-405-PSE	31-405R-PSE	4-1/4"	6-11/16"
6"	2"	1000	PRECISION BALL	31-406-PSE	31-406R-PSE	4-5/8"	7-11/16"
8"	2"	1000	PRECISION BALL	31-408-PSE	31-408R-PSE	5-3/4"	9-3/4"
<b>URETHANE</b>							
3-1/2"	2"	800	ROLLER	31-403.5-TU	31-403.5R-TU	3-1/2"	5-1/16"
4"	2"	900	ROLLER	31-404-TU	31-404R-TU	3-5/8"	5-5/8"
5"	2"	1000	ROLLER	31-405-TU	31-405R-TU	4-1/4"	6-11/16"
6"	2"	1000	ROLLER	31-406-TU	31-406R-TU	4-5/8"	7-11/16"
8"	2"	1000	ROLLER	31-408-TU	31-408R-TU	5-3/4"	9-3/4"
<b>V-GROOVED</b>							
4"	2"	800	ROLLER	31-404-TCV	31-404R-TCV	3-5/8"	5-5/8"
5"	2"	1000	ROLLER	31-405-TCV	31-405R-TCV	4-1/4"	6-11/16"
<b>SEMI - STEEL</b>							
3"	1-7/8"	900	ROLLER	31-403-TCI	31-403R-TCI	3-1/4"	4-3/4"
4"	1-7/8"	1000	ROLLER	31-404-TCI	31-404R-TCI	3-5/8"	5-5/8"
5"	1-7/8"	1000	ROLLER	31-405-TCI	31-405R-TCI	4-1/4"	6-11/16"
6"	1-7/8"	1000	ROLLER	31-406-TCI	31-406R-TCI	4-5/8"	7-11/16"
8"	1-7/8"	1000	ROLLER	31-408-TCI	31-408R-TCI	5-3/4"	9-3/4"

DELRIN™ BEARINGS AVAILABLE IN NEOPRENE (D) AND SOLID ELASTOMER "SE" WHEELS. SUBSTITUTE LETTER "M" FOR LETTER "P"

**FEATURES**



**31-KP408-PSE**

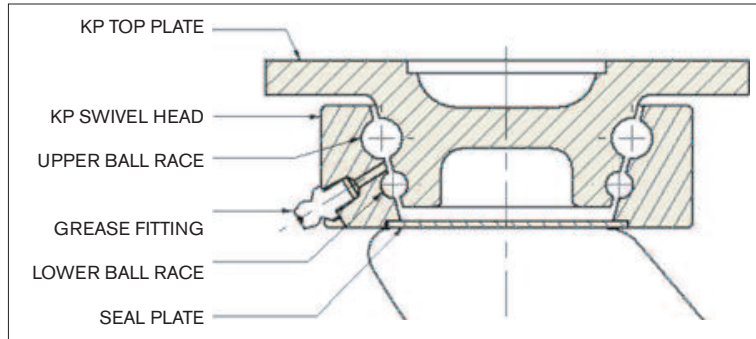

- Heavy duty construction
- High tolerance for shock and impact loading
- Ideal for noise reduction
- Lowest rolling resistance, start and swiveling forces
- Hardened dual-case raceway construction for dependability and durability

**INSTALLATIONS**



**31-KP406-PSE**

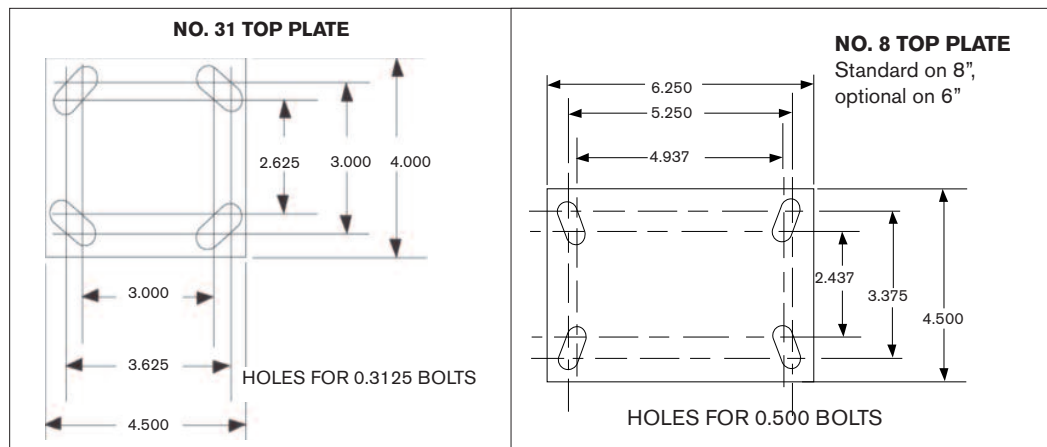

WHEEL DIAMETER	TREAD WIDTH	LOAD CAP./LBS	BEARING TYPE	SWIVEL MODEL	RIGID MODEL	SWIVEL RADIUS	OVERALL HEIGHT
<b>NEOPRENE</b>							
6"	2"	500	ROLLER	31-KP406-TD	31-406R-TD	5-5/8"	7-11/16"
6"	2"	600	PRECISION BALL	31-KP406-PD	31-406R-PD	5-5/8"	7-11/16"
8"	2"	500	ROLLER	8-KP408-TD	31-406R-TD	6-5/8"	9-3/4"
8"	2"	600	PRECISION BALL	8-KP408-PD	31-406R-PD	6-5/8"	9-3/4"
<b>LOW EFFORT URETHANE</b>							
6"	2"	700	PRECISION BALL	31-KP406-PLE	31-406R-PLE	5-5/8"	7-11/16"
8"	2"	800	PRECISION BALL	8-KP408-PLE	31-406R-PLE	6-5/8"	9-3/4"
<b>URETHANE</b>							
6"	1-7/8"	1000	ROLLER	31-KP406-TU	31-406R-TU	5-5/8"	7-11/16"
8"	1-7/8"	1000	ROLLER	8-KP408-TU	31-406R-TU	6-5/8"	9-3/4"
<b>SEMI-STEEL</b>							
6"	1-7/8"	1000	ROLLER	31-KP406-TCI	31-406R-TCI	5-5/8"	7-11/16"
8"	1-7/8"	1000	ROLLER	8-KP408-TCI	31-406R-TCI	6-5/8"	9-3/4"
<b>SOLID ELASTOMER</b>							
6"	2"	1100	PRECISION BALL	31-KP406-PSE	31-406R-PSE	5-5/8"	7-11/16"
8"	2"	1200	PRECISION BALL	8-KP408-PSE	31-406R-PSE	6-5/8"	9-3/4"
<b>SEMI-STEEL</b>							
6"	2"	1200	ROLLER	31-KP406-PSX	31-406R-PSX	5-5/8"	7-11/16"
8"	2"	1300	ROLLER	8-KP408-PSX	31-406R-PSX	6-5/8"	9-3/4"

## FEATURES

- Same robust construction as the single wheeled Kingpinless
  - Modular design allows the addition of one or two wheels
    - dual or triple configuration
- Multi-wheel design produces even lower start, swivel and rolling forces
  - Available in both Darcor proprietary ergonomic wheel materials, Neoprene and Solid Elastomer

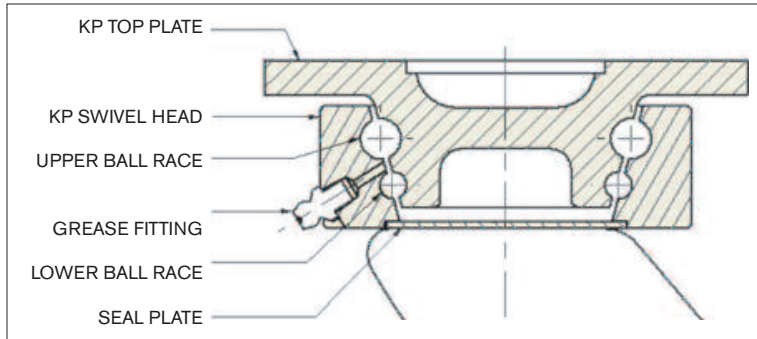

31-KP3406-PD

## INSTALLATIONS

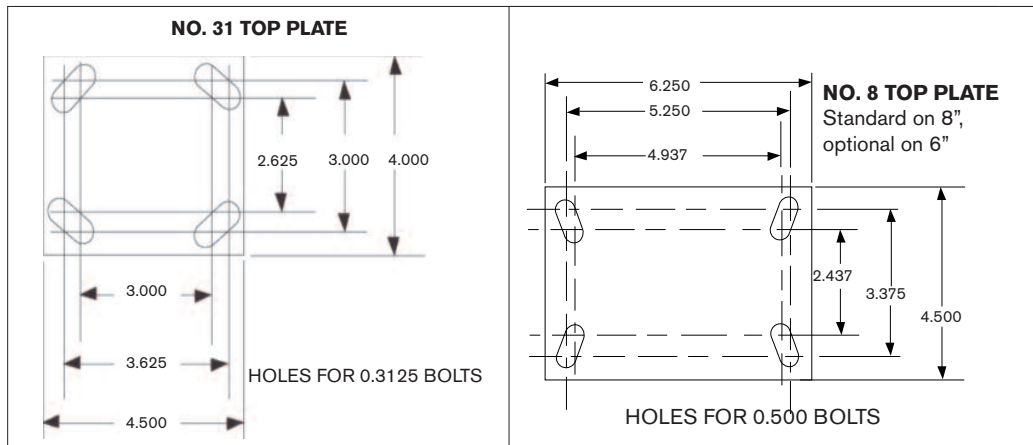

31-2406-PSE

WHEEL DIAMETER	TREAD WIDTH	LOAD CAP./LBS	BEARING TYPE	SWIVEL MODEL	RIGID MODEL	SWIVEL RADIUS	OVERALL HEIGHT
<b>NEOPRENE</b>							
6" DUAL	2"	1000	PRECISION BALL	31-KP2406-PD	31-406R-PD	6-1/2"	7-11/16"
6" TRIPLE	2"	1400	PRECISION BALL	31-KP3406-PD	31-406R-PD	6-1/2"	7-11/16"
8" DUAL	2"	1000	PRECISION BALL	8-KP2408-PD	31-408R-PD	7-3/8"	9-3/4"
8" TRIPLE	2"	1500	PRECISION BALL	8-KP3406-PD	31-408R-PD	7-3/8"	9-3/4"
<b>SOLID ELASTOMER</b>							
6" DUAL	2"	1600	PRECISION BALL	31-KP2406-PSE	31-406R-PSE	6-1/2"	7-11/16"
6" TRIPLE	2"	1800	PRECISION BALL	31-KP3406-PSE	31-406R-PSE	6-1/2"	7-11/16"
8" DUAL	2"	1600	PRECISION BALL	8-KP2408-PSE	31-408R-PSE	7-3/8"	9-3/4"
8" TRIPLE	2"	1800	PRECISION BALL	8-KP3408-PSE	31-408R-PSE	7-3/8"	9-3/4"



8-808-TU

FEATURES

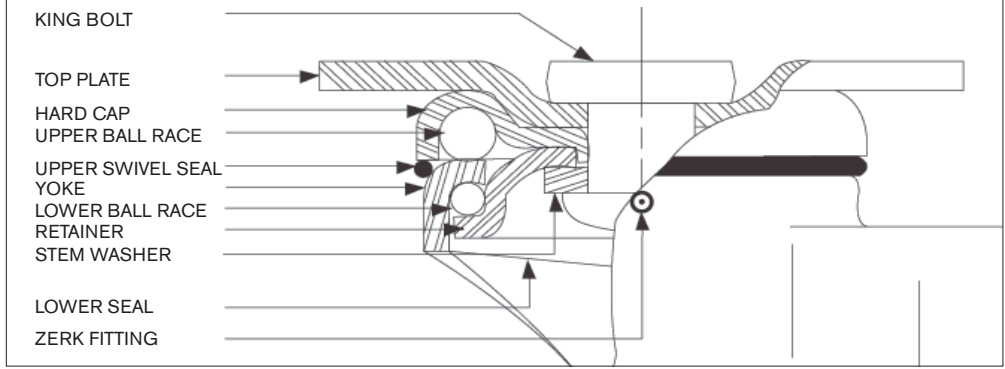

- 3/4" Axle
- 1" King bolt
- Double row ball bearing swivel
- Both raceways equal diameter
- Standard with swivel seals and grease fittings in swivel and axle
- Bright zinc finish
- All swivel parts case hardened to Rockwell 62C

OPTIONS

- Brakes, locks wheel and swivel. Available on 6", 8" and 10" models. Add letter "B".
- Four position swivel locks. Add letter "F".
- Brakes and swivel locks cannot be combined on the same caster.



8-808R-TCI

INSTALLATIONS

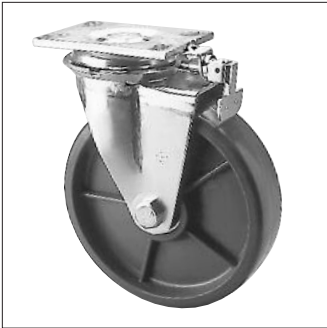

8-810F-PSE

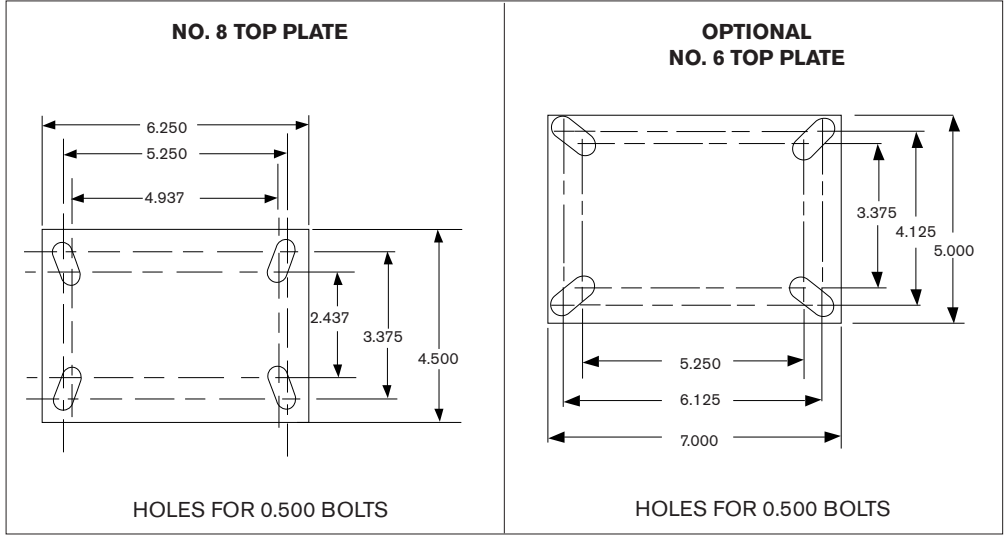

WHEEL DIAMETER	TREAD WIDTH	LOAD CAP./LBS	BEARING TYPE	SWIVEL MODEL	RIGID MODEL	SWIVEL RADIUS	OVERALL HEIGHT
<b>SOLID ELASTOMER</b>							
5"	2-1/2"	1350	PRECISION BALL	8-805-PSE	8-805R-PSE	4-5/8"	7-1/8"
6"	2-1/2"	1500	PRECISION BALL	8-806-PSE	8-806R-PSE	5-1/8"	8-1/8"
8"	2-1/2"	1650	PRECISION BALL	8-808-PSE	8-808R-PSE	6-1/8"	10-1/4"
10"	2-1/2"	1800	PRECISION BALL	8-810-PSE	8-810R-PSE	7-1/8"	12-1/4"
<b>URETHANE</b>							
6"	2-1/4"	1500	ROLLER	8-806-TU	8-806R-TU	5-1/8"	8-1/8"
8"	2-1/2"	1800	ROLLER	8-808-TU	8-808R-TU	6-1/8"	10-1/4"
<b>SEMI-STEEL</b>							
5"	2-1/4"	1500	ROLLER	8-805-TCI	8-805R-TCI	4-5/8"	7-1/8"
6"	2-1/4"	1700	ROLLER	8-806-TCI	8-806R-TCI	5-1/8"	8-1/8"
8"	2-1/4"	1800	ROLLER	8-808-TCI	8-808R-TCI	6-1/8"	10-1/4"
10"	2-1/4"	1800	ROLLER	8-810-TCI	8-810R-TCI	7-1/8"	12-1/4"
<b>V-GROOVED</b>							
6"	2-1/2"	1500	ROLLER	8-806-TCV	8-806R-TCV	5-1/8"	8-1/8"
8"	2-1/2"	1800	ROLLER	8-808-TCV	8-808R-TCV	6-1/8"	10-1/4"



**FEATURES**



6-708-TU

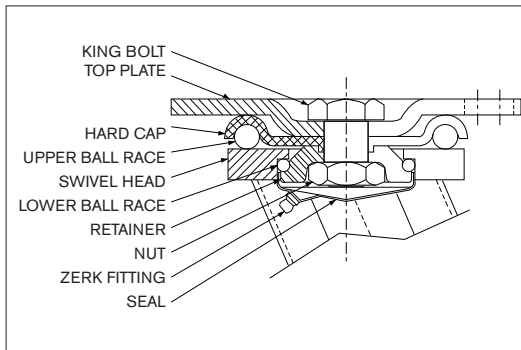

- 3/4" Axle
- 7/8" Grade 8 King bolt
- Double row ball bearing swivel
- Grease fittings in swivel and axle
- Bright zinc finish
- All swivel parts case hardened to Rockwell 62C



6-708R-TU

**OPTIONS**

- Brakes available. Add letter "B".
- Four Position Swivel locks. Add letter "F"
- Brakes and swivel locks cannot be combined on the same castor.

**INSTALLATION**

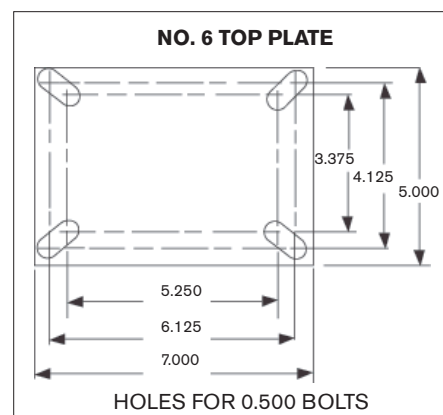

WHEEL DIAMETER	TREAD WIDTH	LOAD CAP./LBS	BEARING TYPE	SWIVEL MODEL	RIGID MODEL	SWIVEL RADIUS	OVERALL HEIGHT
<b>SOLID ELASTOMER</b>							
5"	2-1/2"	1350	PRECISION BALL	6-705-PSE	6-705R-PSE	5-1/8"	7-1/8"
6"	2-1/2"	1500	PRECISION BALL	6-706-PSE	6-706R-PSE	5-5/8"	8-1/8"
8"	2-1/2"	1650	PRECISION BALL	6-708-PSE	6-708R-PSE	6-5/8"	10-1/4"
10"	2-1/2"	1800	PRECISION BALL	6-710-PSE	6-710R-PSE	7-5/8"	12-1/4"
<b>SEMI-STEEL</b>							
5"	2-1/4"	1500	ROLLER	6-705-TCI	6-705R-TCI	5-1/8"	7-1/8"
6"	2-1/4"	1700	ROLLER	6-706-TCI	6-706R-TCI	5-5/8"	8-1/8"
8"	2-1/4"	1800	ROLLER	6-708-TCI	6-708R-TCI	6-5/8"	10-1/4"
10"	2-1/4"	2200	ROLLER	6-710-TCI	6-710R-TCI	7-5/8"	12-1/4"
<b>V-GROOVED</b>							
6"	2-1/2"	1800	ROLLER	6-706-TCV	6-706R-TCV	5-5/8"	8-1/8"
8"	2-1/2"	2000	ROLLER	6-708-TCV	6-708R-TCV	6-5/8"	10-1/4"
<b>URETHANE</b>							
6"	2-1/4"	1500	ROLLER	6-706-TU	6-706R-TU	6-5/8"	8-1/8"
8"	2-1/2"	1800	ROLLER	6-708-TU	6-708R-TU	6/5/8"	10-1/4"

## FEATURES

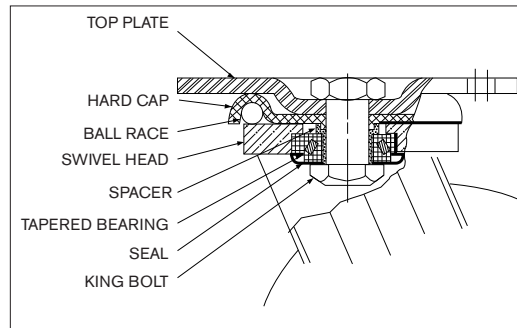

6-908-TN

## INSTALLATION

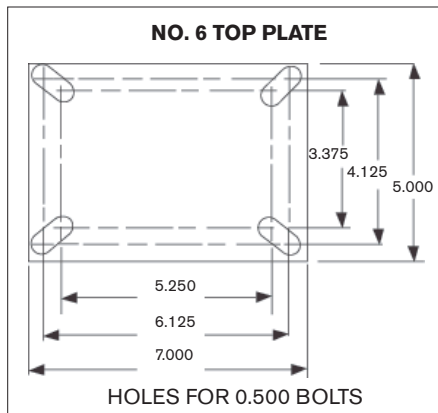

- 3/4" Axle
- 7/8" Grade 8 King bolt
- 4" Diameter upper raceway, 1/2" balls
- 5/8" Thick swivel head, precision machined and equipped with tapered roller bearings
- Ribbed legs for extra strength
- Grease fittings in swivel and wheel
- Bright zinc finish
- All swivel parts case hardened to Rockwell 62C

## OPTIONS

- Brakes available. Add letter "B".
- Four Position Swivel locks. Add letter "F"
- Brakes and swivel locks cannot be combined on the same caster.



6-908B-TCI

WHEEL DIAMETER	TREAD WIDTH	LOAD CAP./LBS	BEARING TYPE	SWIVEL MODEL	RIGID MODEL	SWIVEL RADIUS	OVERALL HEIGHT
<b>SEMI-STEEL</b>							
6"	3"	3500	ROLLER	6-906-TCI	6-906R-TCI	5-5/8"	8-1/4"
6"	3"	3500	TAPERED	6-906-YCI	6-906R-YCI	5-5/8"	8-1/4"
8"	3"	3500	ROLLER	6-908-TCI	6-908R-TCI	6-5/8"	10-1/4"
8"	3"	3500	TAPERED	6-908-YCI	6-908R-YCI	6-5/8"	10-1/4"
10"	3"	3500	ROLLER	6-910-TCI	6-910R-TCI	7-5/8"	12-1/4"
10"	3"	3500	TAPERED	6-910-YCI	6-910R-YCI	7-5/8"	12-1/4"
12"	3"	3500	ROLLER	6-912-TCI	6-912R-TCI	8-5/8"	14-1/4"
12"	3"	3500	TAPERED	6-912-YCI	6-912R-YCI	8-5/8"	14-1/4"
<b>URETHANE</b>							
6"	3"	2500	ROLLER	6-906-TU	6-906R-TU	5-5/8"	8-1/4"
6"	3"	2500	TAPERED	6-906-YU	6-906R-YU	5-5/8"	8-1/4"
8"	3"	3000	ROLLER	6-908-TU	6-908R-TU	6-5/8"	10-1/4"
8"	3"	3000	TAPERED	6-908-YU	6-908R-YU	6-5/8"	10-1/4"
10"	3"	3500	ROLLER	6-910-TU	6-910R-TU	7-5/8"	12-1/4"
10"	3"	3500	TAPERED	6-910-YU	6-910R-YU	7-5/8"	12-1/4"
12"	3"	3500	ROLLER	6-912-TU	6-912R-TU	8-5/8"	14-1/4"
12"	3"	3500	TAPERED	6-912-YU	6-912R-YU	8-5/8"	14-1/4"



5-5008-TU

**FEATURES**

- 1" Axle
- 1" King bolt
- Precision machined swivel head equipped with tapered bearings
- Ribbed legs for strength
- Grease fittings in swivel and wheel



5-5008R-TU

**OPTIONS**

- Brakes available. Add letter "B".
- Four position swivel lock. Add letter "F"
- \*\*Brake and swivel lock can not be combined on the same castor

**INSTALLATION**

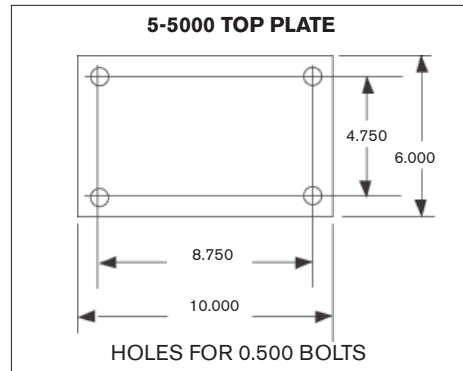

WHEEL DIAMETER	TREAD WIDTH	LOAD CAP./LBS	BEARING TYPE	SWIVEL MODEL	RIGID MODEL	SWIVEL RADIUS	OVERALL HEIGHT
<b>SEMI-STEEL - CROWNED SEMI-STEEL CASTING</b>							
6	3"	5000	ROLLER	5-5006-TCI	5-5006R-TCI	6-1/8"	8-5/8"
6	3"	5000	TAPERED	5-5006-YCI	5-5006R-YCI	6-1/8"	8-5/8"
8	3"	5000	ROLLER	5-5008-TCI	5-5008R-TCI	7-3/8"	10-5/8"
8	3"	5000	TAPERED	5-5008-YCI	5-5008R-YCI	7-3/8"	10-5/8"
10	3"	5000	ROLLER	5-5010-TCI	5-5010R-TCI	8-1/4"	12-5/8"
10	3"	5000	TAPERED	5-5010-YCI	5-5010R-YCI	8-1/4"	12-5/8"
12	3"	5000	ROLLER	5-5012-TCI	5-5012R-TCI	9-3/8"	14-3/4"
12	3"	5000	TAPERED	5-5012-YCI	5-5012R-YCI	9-3/8"	14-3/4"
<b>V-GROOVED</b>							
8	2-5/8"	2000	ROLLER	5-5008-TBCV	5-5008R-TBCV	7-3/8"	10-5/8"
<b>URETHANE</b>							
6	3"	2500	ROLLER	5-5006-TU	5-5006R-TU	6-1/8"	8-5/8"
6	3"	2500	TAPERED	5-5006-YU	5-5006R-YU	6-1/8"	8-5/8"
8	3"	3000	ROLLER	5-5008-TU	5-5008R-TU	7-3/8"	10-5/8"
8	3"	3000	TAPERED	5-5008-YU	5-5008R-YU	7-3/8"	10-5/8"
10	3"	3500	ROLLER	5-5010-TU	5-5010R-TU	8-1/4"	12-5/8"
10	3"	3500	TAPERED	5-5010-YU	5-5010R-YU	8-1/4"	12-5/8"
12	3"	4000	ROLLER	5-5012-TU	5-5012R-TU	9-3/8"	14-3/4"
12	3"	4000	TAPERED	5-5012-YU	5-5012R-YU	9-3/8"	14-3/4"

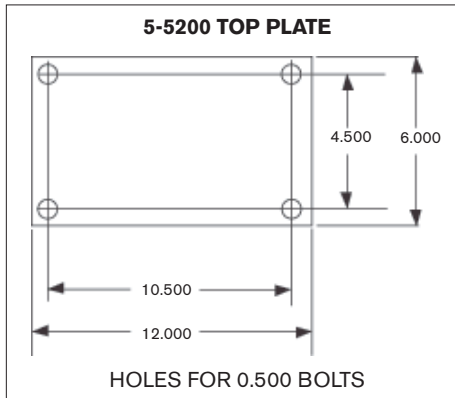
**INSTALLATION****FEATURES**

- 1" Axle
- 1 - 1/4" King bolt
- Dual wheel construction for easier swiveling
- Precision machined swivel head equipped with tapered bearings
- Grease fittings in swivel and wheel

**OPTIONS**

- Swivel locks available. Add letter "F".

**5-5210-TCI****5-5210R-TCI**

WHEEL DIAMETER	TREAD WIDTH	LOAD CAP./LBS	BEARING TYPE	SWIVEL MODEL	RIGID MODEL	SWIVEL RADIUS	OVERALL HEIGHT
<b>SEMI-STEEL</b>							
6"	3"	10000	ROLLER	5-5206-TCI	5-5206R-TCI	5-7/8"	9-7/8"
6"	3"	10000	TAPERED	5-5206-YCI	5-5206R-YCI	5-7/8"	9-7/8"
8"	3"	10000	ROLLER	5-5208-TCI	5-5208R-TCI	6-3/4"	11-3/4"
8"	3"	10000	TAPERED	5-5208-YCI	5-5208R-YCI	6-3/4"	11-3/4"
10"	3"	10000	ROLLER	5-5210-TCI	5-5210R-TCI	7-5/8"	13-3/4"
10"	3"	10000	TAPERED	5-5210-YCI	5-5210R-YCI	7-5/8"	13-3/4"
12"	3"	10000	ROLLER	5-5212-TCI	5-5212R-TCI	8-5/8"	15-3/4"
12"	3"	10000	TAPERED	5-5212-YCI	5-5212R-YCI	8-5/8"	15-3/4"
<b>URETHANE</b>							
6"	3"	5000	ROLLER	5-5206-TU	5-5206R-TU	5-7/8"	9-7/8"
6"	3"	5000	TAPERED	5-5206-YU	5-5206R-YU	5-7/8"	9-7/8"
8"	3"	6000	ROLLER	5-5208-TU	5-5208R-TU	6-3/4"	11-3/4"
8"	3"	6000	TAPERED	5-5208-YU	5-5208R-YU	6-3/4"	11-3/4"
10"	3"	7000	ROLLER	5-5210-TU	5-5210R-TU	7-5/8"	13-3/4"
10"	3"	7000	TAPERED	5-5210-YU	5-5210R-YU	7-5/8"	13-3/4"
12"	3"	8000	ROLLER	5-5212-TU	5-5212R-TU	8-5/8"	15-3/4"
12"	3"	8000	TAPERED	5-5212-YU	5-5212R-YU	8-5/8"	15-3/4"



31-405-TCV

**FEATURES**

- High quality semi-steel wheels, machined to close tolerances
- Economical handling of heavy loads
- Floor protection
- Adaptability, (will roll on track or floor)
- Free rolling on sediment covered floors as the angle iron track is self cleaning

**OPTIONS AND INSTALLATIONS**

WHEEL DIAMETER	TREAD WIDTH	LOAD CAP./LBS	BEARING TYPE	SWIVEL MODEL	RIGID MODEL	SWIVEL RADIUS	OVERALL HEIGHT
3"	1-1/4"	300	SLEEVE	16-63-CV	16-63R-CV	2-3/4"	4-5/16"
4"	1-3/8"	500	ROLLER	31-74-TCV	31-74R-TCV	3-1/2"	5-9/16"
4"	2"	800	ROLLER	31-404-TCV	31-404R-TCV	3-5/8"	5-5/8"
5"	1-1/2"	600	ROLLER	31-75-TCV	31-75R-TCV	4"	6-5/8"
5"	2"	1000	ROLLER	31-405-TCV	31-405R-TCV	4-1/4"	6-11/16"
6"	2-1/2"	1500	ROLLER	8-806-TCV	8-806R-TCV	5-1/8"	8-1/8"
8"	2-1/2"	1800	ROLLER	8-808-TCV	8-808R-TCV	6-1/8"	10-1/4"
8"	2-5/8"	2000	ROLLER	5008-TBCV	5008R-TBCV	7-3/8"	10-5/8"



31-75R-TCV

**WHEEL DIMENSIONS**

WHEEL DIAMETER	TREAD WIDTH	LOAD CAP./LBS	WHEEL MODEL	BEARING TYPE	BORE SIZE	HUB LENGTH	USED IN CASTER SERIES
3"	1-1/4"	300	W-63-CV	SLEEVE	3/8"	1-1/2"	60
4"	1-3/8"	500	W-74-TCV	ROLLER	3/8"	1-3/4"	70
4"	2"	800	W-404-TCV	ROLLER	1/2"	2-5/16"	400
5"	1-1/2"	600	W-75-TCV	ROLLER	3/8"	1-3/4"	70
5"	2"	1000	W-405-TCV	ROLLER	1/2"	2-5/16"	400
6"	2-1/2"	1500	W-806-TCV	ROLLER	3/4"	2-3/4"	700/800
8"	2-1/2"	1500	W-808-TCV	ROLLER	3/4"	2-3/4"	700/800
8"	2-5/8"	2000	W-5008-TCV	ROLLER	3/4"	3-1/4"	900/5000

**WHEEL DRAWINGS**

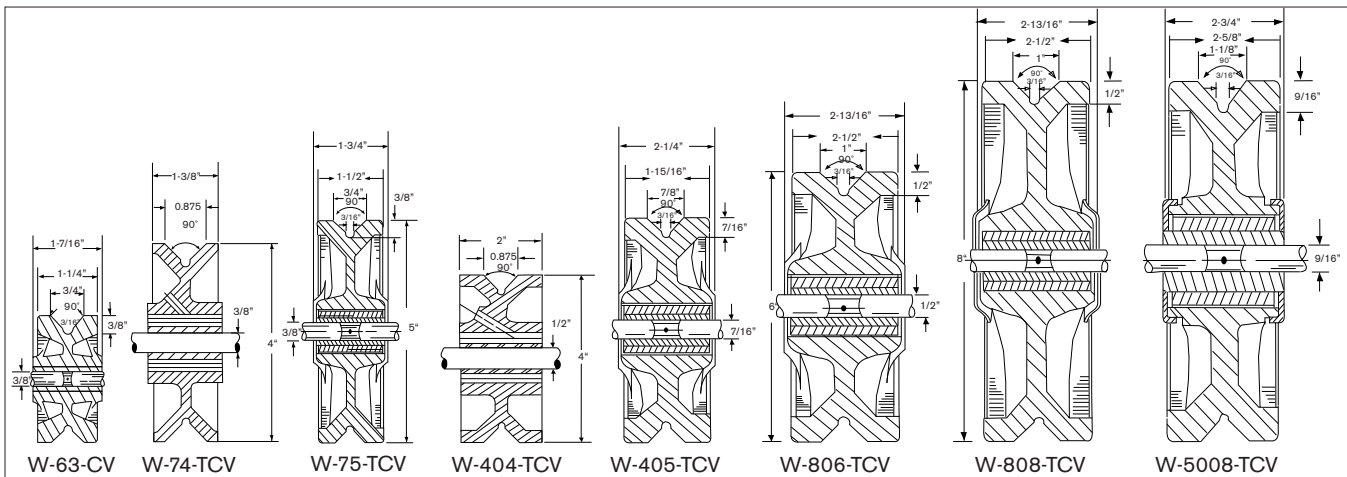

# SPRING LOADED CASTERS

## 31-SL 400 SERIES

### INSTALLATION

#### NO. 31 TOP PLATE (STANDARD ON 400 SERIES)

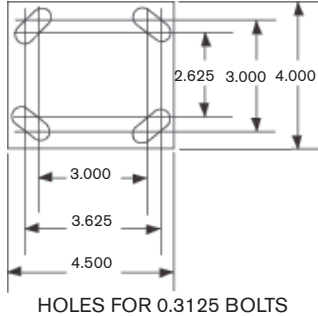

### FEATURES

- Oil impregnated permanently lubricated sintered bearings for all moving parts
- Sealed precision ball bearings in the wheel permanently lubricated for long life and low rolling resistance
- Sealed swivel assembly with grease fitting for ease of access
- Load rating 1000 pounds at maximum spring deflection
- Various mounting plates available

Available in 3", 4", 5", 6", and 8" models



31-SL404-PSE

WHEEL DIAMETER	TREAD WIDTH	LOAD CAP./LBS	BEARING TYPE	MODEL NUMBER	SWIVEL RADIUS	OVERALL HEIGHT NO LOAD	OVERALL HEIGHT MAX. LOAD
<b>SOLID ELASTOMER</b>							
3"	2"	900	PRECISION BALL	31-SL403-PSE	3.50"	7.00"	6.00"
4"	2"	900	PRECISION BALL	31-SL404-PSE	4.00"	7.50"	6.50"
5"	2"	1000	PRECISION BALL	31-SL405-PSE	4.85"	9.00"	8.00"
6"	2"	1000	PRECISION BALL	31-SL406-PSE	5.30"	9.50"	8.50"
8"	2"	800	PRECISION BALL	31-SL408-PSE	7.30"	11.50"	10.00"
<b>NEOPRENE</b>							
4"	2"	450	PRECISION BALL	31-SL404-PD	4.00"	7.50"	6.50"
5"	2"	500	PRECISION BALL	31-SL405-PD	4.85"	9.00"	8.00"
6"	2"	550	PRECISION BALL	31-SL406-PD	5.30"	9.50"	8.50"
8"	2"	550	PRECISION BALL	31-SL408-PD	7.30"	11.50"	10.00"

### INSTALLATION

#### NO. 6 TOP PLATE

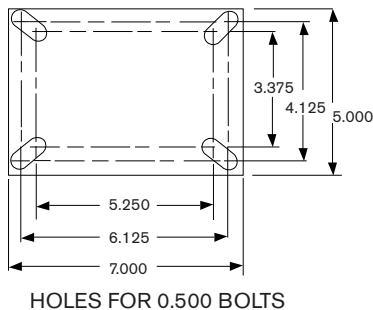

## 6-SL 900 SERIES

### FEATURES

- Oil impregnated permanently lubricated sintered bearings for all moving parts
- Tapered bearings in swivel
- Load rating to 2500 lbs
- Available in 5", 8", and 10" models
- Can be manufactured in additional sizes as required



6-SL908-YU

WHEEL DIAMETER	TREAD WIDTH	LOAD CAP./LBS	BEARING TYPE	MODEL NUMBER	SWIVEL RADIUS	OVERALL HEIGHT NO LOAD	OVERALL HEIGHT MAX. LOAD
5"	2-1/2"	1000	PRECISION BALL	6-SL905-PSE	4.50"	10.00"	7.25"
8"	3"	2500	TAPERED	6-SL908-YU	6.90"	13.00"	12.00"
10"	3"	2500	TAPERED	6-SL910-YU	8.60"	15.00"	14.00"



## SPRING LOADED CASTERS

### SL 8510-YU



SL-8510-YU

#### FEATURES

- Oil impregnated bearings in all pivoting points
- Grease fitting in swivel and wheel
- Sealed bearings in wheel
- Tapered bearings in swivel head and wheel
- Four position swivel locks and brakes available

#### INSTALLATION

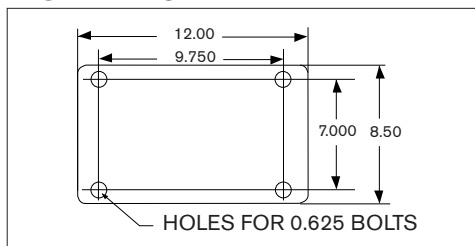

WHEEL DIAMETER	TREAD WIDTH	LOAD CAP./LBS	BEARING TYPE	MODEL NUMBER	SWIVEL RADIUS	OVERALL HEIGHT NO LOAD	OVERALL HEIGHT MAX. LOAD
10"	5"	10,000	TAPERED	SL8510-YU	9.40"	15.625"	14.50"

### TWIN WHEEL

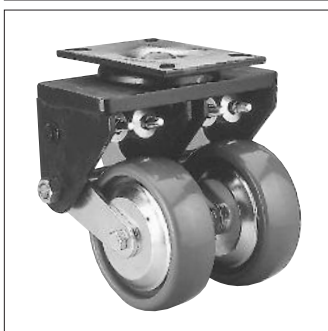

6-TSL2406-PSE

#### FEATURES

- Twin wheels reduced resistance to swiveling
- Twin wheels spread load over a wider area
- Twin wheels offer higher load carrying capacity
- Available with swivel locks

#### INSTALLATION

No. 6 and 5200 top plates

WHEEL DIAMETER	TREAD WIDTH	LOAD CAP./LBS	BEARING TYPE	MODEL NUMBER	SWIVEL RADIUS	OVERALL HEIGHT NO LOAD	OVERALL HEIGHT MAX. LOAD
6"	2"	2200	PRECISION BALL	6-TSL2406-PSE	6.35"	9.45"	8.45"

### GATE CASTERS



QSL-22-XD



QSL-32-XD

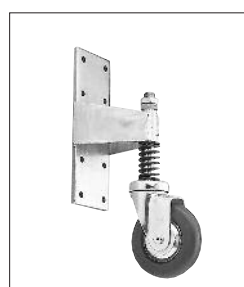

QSL-75-XD

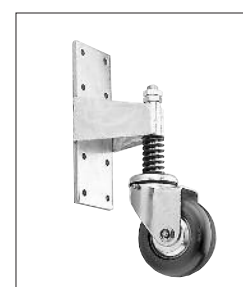

QSL-405-TD

WHEEL DIAMETER	CASTER MODEL NO.	OVERALL HEIGHT NO LOAD	OVERALL HEIGHT MAX. LOAD	SWIVEL OFFSET C/W BRACKET	LOAD CAPACITY
2"	QSL-22-XD	7.375"	6.375"	1.750"	18 lbs.
2"	QSL-32-XD	8.500"	7.625"	3.500"	200 lbs.
5"	QSL-75-XD	13.250"	12.000"	5.375"	300 lbs.
5"	QSL-405-TD	13.250"	12.000"	5.375"	400 lbs.

## LIFT TRUCK APPLICATIONS

## FEATURES

Darcor offers a unique line of Spring Loaded Casters for lift trucks. Ergonomically designed, these easy to maneuver casters offer the utmost in superior performance. Darcor "SE" Solid Elastomer Wheels are chemical resistant and show minimal wear or heat buildup in extended use. Spring Loaded Casters equipped with SE wheels feature precision sealed ball bearings and require little maintenance. Darcor also supplies "high quality" Polyurethane wheels with tapered bearings for heavier loads and varying speed conditions.



LT1



LT2



LT3



LT4

WHEEL DIAMETER	TREAD WIDTH	LOAD CAP./LBS	BEARING TYPE	MODEL NUMBER	SWIVEL RADIUS	OVERALL HEIGHT NO LOAD	OVERALL HEIGHT MAX. LOAD
4"	2"	800	PRECISION BALL	LT2	4.125	7.375"	6.375"
4"	2-1/2"	1200	PRECISION BALL	LT1	5	8.66"	7.66"
4"	2-1/2"	1000	PRECISION BALL	LT3	4	7.56"	6.56"
6"	2-1/2"	1000	PRECISION BALL	LT4	5	11.4"	10.4"

- Pre-loading and custom spring rates/capacity available as special order.



**31-CW76-XD**



**31-CW76B-XD**



**31-CW76R-XD**



**31-CW76F-XSR**

**FEATURES**

After years of actual experiments and hundreds of tests, we have developed a line of casters to reduce rusting under wet conditions. Hospital laundries and dietary departments, plus hotel and motel areas concerned with sanitary operations will find the cartwashable design reduces maintenance and provides extra life both to the casters and equipment. The medium and heavy duty models are ideally suited to the sanitary conditions dictated by experimental and pharmaceutical laboratories as well as firms connected to the meat packing and food industries.

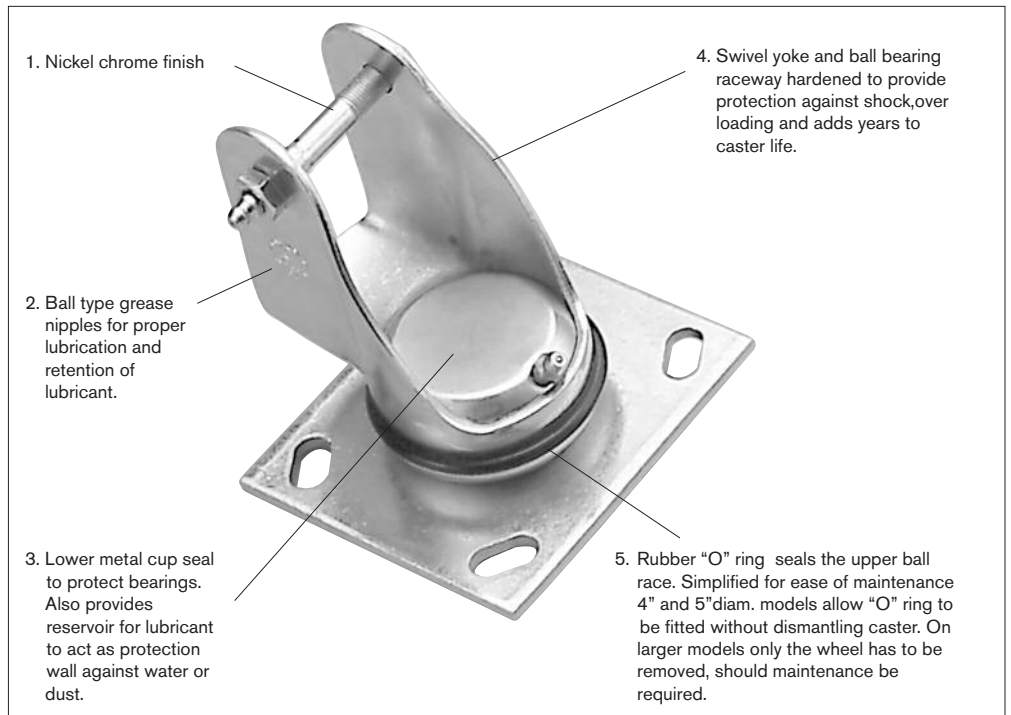

**INSTALLATIONS**

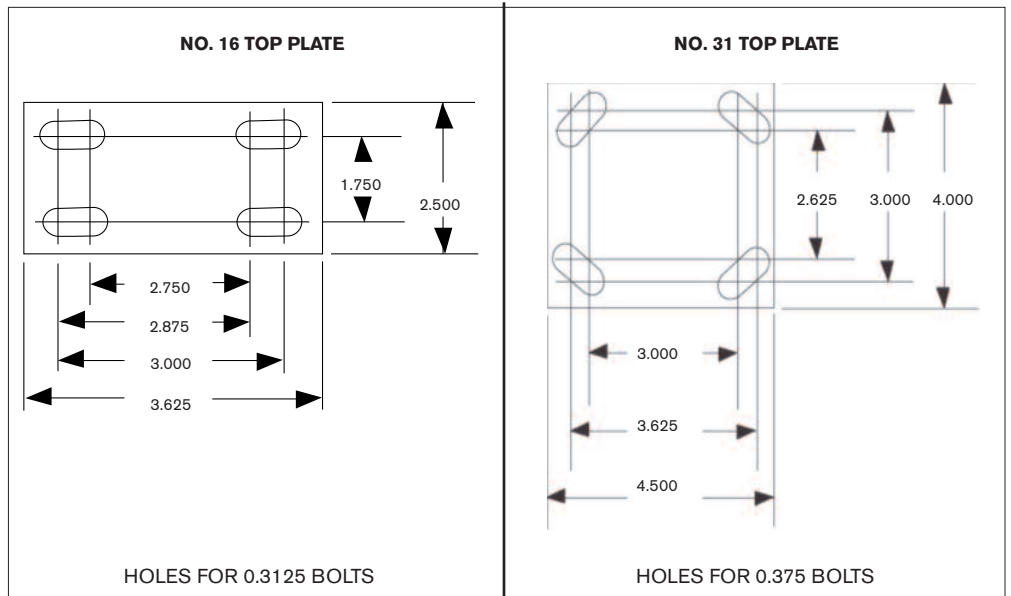

OPTIONAL STEMS AND PLATES AVAILABLE UPON REQUEST.  
 CARTWASHABLE™ IS A REGISTERED TRADEMARK OF DARCOR LIMITED.

# CARTWASHABLE™ SERIES

## CASTERS

WHEEL DIA.	TREAD WIDTH	LOAD CAP./LBS	BEARING TYPE	SWIVEL MODEL	RIGID MODEL	SWIVEL RADIUS	OVERALL HEIGHT
<b>NEOPRENE</b>							
4"	1-3/8"	225	BALL	16-CW64-XD	16-CW64R-XD	3-1/4"	5-3/8"
4"	1-3/8"	250	BALL	31-CW74-XD	31-CW74R-XD	3-1/2"	5-9/16"
5"	1-3/8"	250	BALL	16-CW65-XD	16-CW65R-XD	4"	6-3/8"
5"	1-3/8"	275	BALL	31-CW75-XD	31-CW75R-XD	4"	6-5/8"
5"	2"	450	ROLLER	31-CW405-TD	31-CW405R-TD	4-1/4"	6-11/16"
5"	2"	550	PRECISION BALL	31-CW405-PD	31-CW405R-PD	4-1/4"	6-11/16"
6"	1-5/8"	300	BALL	31-CW76-XD	31-CW76R-XD	4-7/8"	7-9/16"
6"	2"	500	ROLLER	31-CW406-TD	31-CW406R-TD	4-5/8"	7-11/16"
6"	2"	600	PRECISION BALL	31-CW406-PD	31-CW406R-PD	4-5/8"	7-11/16"
8"	2"	500	ROLLER	31-CW408-TD	31-CW408R-TD	5-3/4"	9-3/4"
8"	2"	600	PRECISION BALL	31-CW408-PD	31-CW408R-PD	5-3/4"	9-3/4"
<b>SUPER ROLL NEOPRENE</b>							
4"	1-3/8"	250	BALL	16-CW64-XSR	16-CW64R-XSR	3-1/4"	5-3/8"
4"	1-3/8"	300	BALL	31-CW74-XSR	31-CW74R-XSR	3-1/2"	5-9/16"
5"	1-3/8"	275	BALL	16-CW65-XSR	16-CW65R-XSR	4"	6-3/8"
5"	1-3/8"	350	BALL	31-CW75-XSR	31-CW75R-XSR	4"	6-5/8"
6"	1-1/2"	400	BALL	31-CW76-XSR	31-CW76R-XSR	4-7/8"	7-9/16"
<b>SOLID ELASTOMER</b>							
4"	1-3/8"	600	PRECISION BALL	31-CW74-PSE	31-CW74R-PSE	3-1/2"	5-9/16"
5"	1-3/8"	600	PRECISION BALL	31-CW75-PSE	31-CW75R-PSE	4"	6-5/8"
5"	2"	1000	PRECISION BALL	31-CW405-PSE	31-CW405R-PSE	4-1/4"	6-11/16"
6"	1-3/8"	600	PRECISION BALL	31-CW76-PSE	31-CW76R-PSE	4-7/8"	7-9/16"
6"	2"	1000	PRECISION BALL	31-CW406-PSE	31-CW406R-PSE	4-5/8"	7-11/16"
8"	2"	1000	PRECISION BALL	31-CW408-PSE	31-CW408R-PSE	5-3/4"	9-3/4"

## WHEELS

WHEEL DIA.	TREAD WIDTH	LOAD CAP./LBS	BALL BEARING	ROLLER BEARING	PRECISION BALL BEARING SEALED	BORE SIZE	HUB LENGTH	SERIES USED IN
<b>NEOPRENE WHEELS</b>								
4"	1-3/8"	225	W-CW64-XD			3/8"	1-1/2"	60
4"	1-3/8"	250	W-CW74-XD			3/8"	1-3/4"	70
5"	1-3/8"	250	W-CW65-XD			3/8"	1-1/2"	60
5"	1-3/8"	275	W-CW75-XD			3/8"	1-3/4"	70
5"	2"	450/550		W-CW405-TD	W-CW405-PD	1/2"	2-3/8"	400
6"	1-1/2"	300	W-CW76XD			3/8"	1-3/4"	70
6"	2"	500/600		W-CW406-TD	W-CW406-PD	1/2"	2-3/8"	400
8"	2"	500/600		W-CW408-TD	W-CW408-PD	1/2"	2-3/8"	400
<b>SUPER ROLL NEOPRENE</b>								
4"	1-3/8"	250	W-CW64-XSR			3/8"	1-1/2"	60
4"	1-3/8"	300	W-CW74-XSR			3/8"	1-3/4"	70
5"	1-3/8"	275	W-CW65-XSR			3/8"	1-1/2"	60
5"	1-3/8"	350	W-CW75-XSR			3/8"	1-3/4"	70
6"	1-1/2"	400	W-CW76-XSR			3/8"	1-3/4"	70
<b>SOLID ELASTOMER WHEELS</b>								
4"	1-3/8"	600			W-CW74-PSE	3/8"	1-3/4"	70
5"	1-3/8"	600			W-CW75-PSE	3/8"	1-3/4"	70
5"	2"	1000			W-CW405-PSE	1/2"	2-3/8"	400
6"	1-3/8"	600			W-CW76-PSE	3/8"	1-3/4"	70
6"	2"	1000			W-CW406-PSE	1/2"	2-3/8"	400
8"	2"	1000			W-CW408-PSE	1/2"	2-3/8"	400

# SPECIAL APPLICATION CASTERS

## FEATURES

The following are just a few of our special application casters. They have been designed to meet specific requirements of customers by our engineering department. These applications are found in many different areas of industry so we feel it is important to show these casters in their own section of our catalogue. We hope they will offer you a solution to your own unusual or special application problems. We encourage you to call us if you don't find the caster you require in our catalogue.



**8216-YU**

16,800 lbs. capacity caster with twin 16" x 5" polyurethane wheels. Extra heavy assembly designed to withstand extreme thrust on king pin. Presently being used in the mining industry OH 21-3/4".



**9K**

20,000 lbs. capacity steel wheel caster with an overall height of just 1/2". This caster was designed to move a large heavy load in a confined area where overall height was restricted. Available in swivel and rigid models, it can be supplied in larger sizes as well.



**TURTLE™**

"Turtle" Caster designed for load ratings from 600 lbs. to 2,500 lbs. Equipped with 3 swivel casters mounted to a swivel head. Good for low heights and heavy loads. Reduced swivel effort gives a smooth gliding action while protecting floor surfaces. Excellent choice for applications such as studio, theatre and stage equipment.



**31-224-XD**

300 lbs. twin wheel caster available with either 3" or 4" diameter wheels and can be supplied with any fittings applicable to the 70 series. The twin wheels offer easier swiveling and are ideal for equipment going on and off elevators where single wheel casters tend to get caught in the entrance.



**31-274-PSE**

1200 - 2000lbs twin wheel casters, equipped with solid elastomer sealed precision ball bearing wheels. Twin wheels maintain a low profile while providing easy pivoting action. Good for heavy loads, offering ease of movement over floor gaps and joints. Excellent for continuous use operations such as tow lines, and Automatic Guided Vehicles.



**8-2404-PSE**

TURTLE™ IS A REGISTERED TRADEMARK OF DARCOR LIMITED.

Darcor manufactures a complete line of ergonomically designed casters for medical and diagnostic equipment such as portable x-ray machines, MRI's and ultrasound machines. Darcor's twin wheel casters – featuring directional locks, brakes and central locking systems – are available with either LE or Neoprene wheels, which are quiet, non-marking and shock absorbent. Darcor is proud to manufacture a complete line of products that exceed current medical industry standards.



#### M6 SERIES

The Darcor M6 incorporates an advanced caster design and central locking mechanism that makes it an excellent choice for transporting the most sensitive diagnostic equipment. It can be custom-configured to meet the customer's precise specifications.



#### M5 SERIES

The robust, twin-wheel design of the M5 caster makes it ideal for applications, such as bariatric beds, where strength and maneuverability are critical. Equipped with shock-dampening wheels to cushion its load, the M5 is widely used in health-care facilities around the world.

SERIES	INSTALLATION	WHEEL DIA.	TREAD WIDTH	LOAD CAP./LBS	BRG TYPE SWIVEL/WHEEL	BRAKE MODEL	SWIVEL MODEL	SW. RAD	O.A.H.
M5	TOP PLATE	5"	1"	300	PRECISION/BALL	T-CLM5-XD	T-M5-XD	4-5/8"	6-7/8"
	STEM	5"	1"	300	PRECISION/BALL	S-CLM5-XD	S-M5-XD	4-5/8"	5-7/8"
M6	TOP PLATE	6"	7/10"	250	PRECISION/PRECISION	T-CLM6-PD	T-M6-PD	5-3/8"	8"
	STEM	6"	7/10"	250	PRECISION/PRECISION	S-CLM6-PD	S-M6-PD	5-3/8"	7"

Mounting Option: Stem Diameter 1.1" (28 mm) Available as CL (Industry STD)

Wheel Option: Neoprene (LE as special order)

Finish: Off White on M5 models  
Grey on M6 models

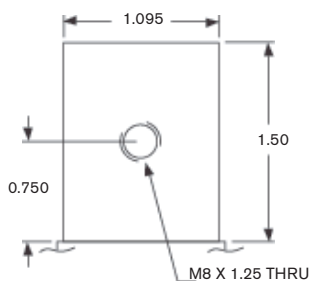

SWIVEL STEM

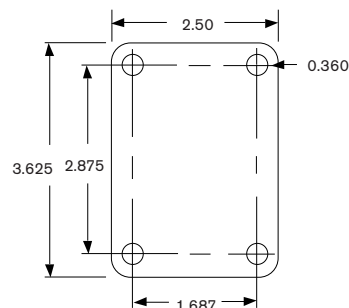

TOP PLATE

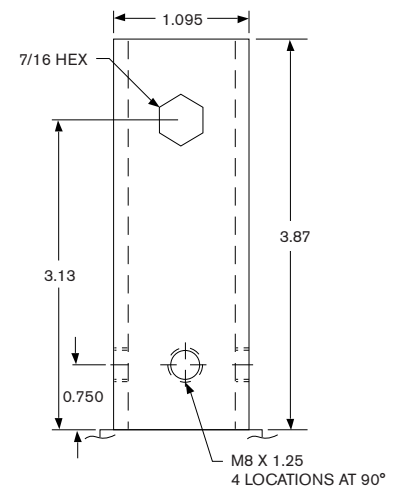

CENTRAL LOCK STEM  
(BRAKE MODEL)





**FEATURES**

- The worlds first single button, triple-function caster
- One foot pedal controls free swivel, swivel lock and total lock
- Hardened ball bearing race and precision ball bearings in the wheel
- Ideal solution for ultrasound, mobile x-ray and anesthesiology machines
- One of the lowest starting, rolling and swiveling forces in the industry



**INSTALLATION**

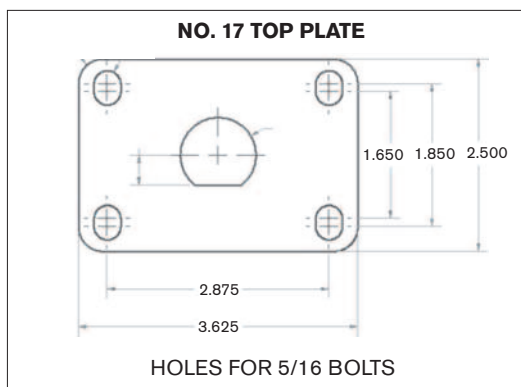

WHEEL DIAMETER	TREAD WIDTH	LOAD CAP./LBS	BEARING TYPE	3-POSITION MODEL	SWIVEL MODEL	SWIVEL RADIUS	OVERALL HEIGHT
<b>NEOPRENE SUPER ROLL - STANDARD WHEEL</b>							
6"	1-1/2"	400	PRECISION	17-MED6A-PSR	17-MED6PSR	5"	7 - 1/2"
<b>NEOPRENE - OPTIONAL WHEEL</b>							
6"	1-1/2"	300	PRECISION	17-MED6A-PD	17-MED6PD	5"	7 - 1/2"

# HOSPITAL BED CASTER SERIES

## FEATURES

Designed with a cam action locking mechanism, the lever easily engages and disengages with the touch of a toe. As well as offering easy access, the lever design keeps it within the swivel radius of the caster, eliminating any interference. The assembly is available with nickel chrome finish (BC5) or zinc finish (BC45) and equipped with our non-marking Super Roll neoprene wheel complete with ball bearings.



OU125-BC5B2-XSR



OU-BC65B-XSR



OU-BC5-XSR

### KEYWAY SOCKETS AND STEM -

Prevents stem from turning inside socket. For use with hospital bed total lock brakes.

- CSK 125 - Fits inside 1-1/4" 14 Gauge square tubing
- CSK 150 - Fits inside 1-1/2" 18 Gauge square tubing
- CSK 158 - Fits inside 1-5/8" 16 Gauge round tubing

### ADAPTER AND STEM LOCK SOCKET -

Prevents stem from turning. For use with hospital bed total lock brakes.

- OU 125 - Fits over 1-1/4" OD square tubing
- OU 150 - Fits over 1-1/2" OD square tubing

#### KEYWAY SOCKET AND STEM

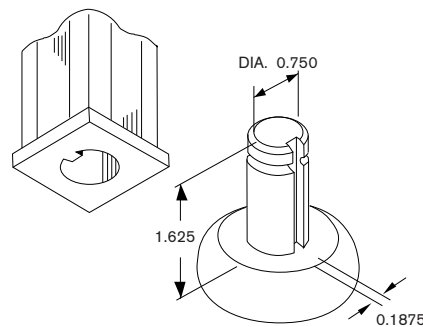

#### ADAPTER AND STEM LOCK SOCKET

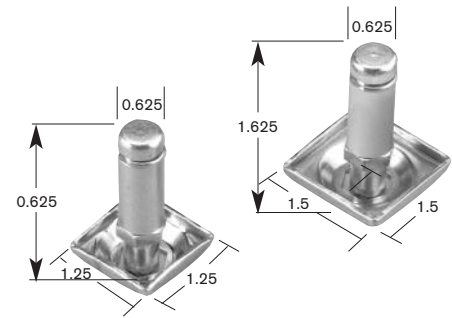

WHEEL DIAMETER	TREAD WIDTH	LOAD CAP./LBS	BEARING TYPE	SWIVEL MODEL	BRAKE MODEL	SWIVEL RADIUS	OVERALL HEIGHT
<b>NEOPRENE SUPER ROLL</b>							
4"	1-3/8"	275	BALL	OU-BC64-XSR	OU-BC64B-XSR*	3-1/4"	5-3/8"
5"	1-3/8"	325	BALL	OU-BC65-XSR	OU-BC65B-XSR*	4"	6-3/8"

- B2 brake casters available on BC64 and BC65 casters with additional charge.

- All bed casters shown with OU 5/8" x 1-5/8" grip ring stem, optional stems and sockets as shown. Also available with all 60 series stems and top plates see pages 14,15 and 16.

\* Stems should be secured on brake casters to prevent turning when swivel lock is engaged.

## NEOPRENE WHEELS



W-76-XD

### NEOPRENE FEATURES

**NEOPRENE  
TREAD SYMBOL "D"  
DUROMETER - SHORE 62 "A"**

Superior for all floor surfaces and ergonomically designed for excellent mobility and resistance to wear. These quiet and easy rolling wheels are very shock absorbing, non-marking and will reject floor debris, roll over screws, metal or glass fragments, resin pellets and are non-staining. Darcor precision ball bearings are standard in the 20 through 70 series. Precision ball bearings "P" are recommended in the 400 series. Sizes available 2" to 8".



W-76-XSR

### NEOPRENE SUPER ROLL FEATURES

**NEOPRENE  
TREAD SYMBOL "SR"  
DUROMETER - SHORE 62 "A"**

The "SR" wheels offer the same high quality as "D" wheels but with a low profile tread for easier swiveling and very low rolling resistance.

- Shore Hardness 59-63 "A" Scale
- Non marking and non staining
- Temperature ranges 300° F for 20 minutes, 175° F for 1 hour
- Highly resistant to wax, oils, greases, cleaning compounds, weather and ozone.
- Can be used on all floor surfaces
- Does not flat spot when sitting for long periods under load

\* All Darcor "D" and "SR" wheels are mold-on wheels with a neoprene tread thermally bonded to a glass fibre reinforced nylon core for exceptional strength, impact resistance and outstanding rollability.

### NEOPRENE WHEEL CHEMICAL RESISTANCE GUIDE

This table lists a broad range of fluids and chemicals which are considered compatible with our Neoprene wheel. Ratings are at 72°F unless specified otherwise. Concentrations of aqueous solutions are saturated, except where noted. Note especially that this data is based on laboratory tests and may vary in practice. Field testing is suggested to confirm these recommendations. Only those chemicals that have little or no effect on the Neoprene wheel are listed here. Other fluids may have a very minor or major effect. For information on the compatibility of other fluids contact engineering.

Acetic acid, 20%	Castor oil	Hydrochloric acid, 20%	Potassium hydroxide, dilute solutions
Acetic acid, 30%	Chlorine gas, dry	Hydrochloric acid, 37%	Sea water
Acetic anhydride	Chloroacetic acid	Hydrocyanic acid	Silicone grease
Acetone	Citric acid solutions	Hydrofluoric acid, up to 75%	Soap solutions
Acetylene	Copper chloride solutions	Hydrofluoric acid, anhydrous	Sodium chloride solutions
Aluminium chloride solutions	Copper sulfate solutions	Hydrogen	Sodium dichromate, 20%
Aluminium sulfate solutions	Cottonseed oil	Hydrogen peroxide, 90%	Sodium hydroxide, up to 23%
Ammonia, anhydrous	DOWTHERM A	Hydrogen sulfide	Sodium hydroxide, 46½%
Ammonium chloride solutions	Ethyl alcohol	Isooctane	Sodium hypochlorite, up to 20%
Ammonium hydroxide solutions	Ethylene glycol	Isopropyl alcohol	Sodium peroxide solutions
Ammonium sulfate solutions	Ferric chloride solutions	Lactic acid	Soybean oil
Amyl alcohol	Fluosilicic acid	Linseed oil	Stannic chloride
ASTM oil #1	Formaldehyde, 40%	Lubricating oils	Stannous chloride, 15%
ASTM oil #3	Formic acid	Magnesium chloride solutions	Steam
ASTM reference fuel A	FREON*-11	Magnesium hydroxide solutions	Stearic acid
Asphalt	FREON-11	Mercuric chloride solutions	Sulfur, molten
Barium hydroxide solutions	FREON-12	Mercury	Sulfur dioxide, gas
Beer	FREON-22	Methyl alcohol	Sulfur dioxide, liquid
Borax solutions	FREON-22 (130°F)	Mineral oil	Sulfuric acid, up to 60%
Boric acid solutions	FREON-113	Nitric acid, 10%	Tannic acid, 10%
Butane	FREON-113 (130°F)	Oleic acid	Tartaric acid
Butyraldehyde	FREON-114	Palmitic acid	Triethanolamine
Calcium bisulfite solutions	FREON-114 (130°F)	Phosphoric acid, 20%	Trisodium phosphate solutions
Calcium chloride solutions	Furfural	Phosphoric acid, 60%	Tung oil
Calcium hydroxide solutions	Gasoline	Phosphoric acid, 70%	Water
Calcium hypochlorite, up to 20%	Glue	Phosphoric acid, 85%	Zinc chloride solutions
Carbon dioxide	Glycerin	Pitric acid	
Carbon monoxide	n-Hexane	Potassium dichromate solutions	

## NEOPRENE WHEELS

WHEEL DIAMETER	TREAD WIDTH	LOAD CAP./LBS	BALL BEARING	ROLLER BEARING	PRECISION SEALED BALL BEARING	BORE SIZE	HUB LENGTH	USED IN CASTER SERIES
<b>NEOPRENE WHEELS</b>								
2"	1"	75	W-22-XD			5/16"	1-1/8"	20 ETERNITY 2
2"	1"	150	W-32-XD			5/16"	1-1/8"	30
3"	1"	75	W-53-XD			5/16"	1-1/8"	CARPET MASTER
3"	1"	75	W-23-XD			5/16"	1-1/8"	20
3"	1-3/8"	200	W-63-XD			3/8"	1-1/2"	60
3"	1-3/8"	225	W-73-XD			3/8"	1-3/4"	70
3-1/2"	1-3/8"	200	W-63.5-XD			3/8"	1-1/2"	60
4"	1"	75	W-24-XD			5/16"	1-1/8"	20
4"	1-3/8"	225	W-64-XD			3/8"	1-1/2"	60
4"	1-3/8"	250	W-74-XD			3/8"	1-3/4"	70
4"	2"	400/500		W-404-TD	W-404-PD	1/2"	2-5/16"	400
5"	1"	75	W-25-XD			5/16"	1-1/8"	20
5"	1-3/8"	250	W-65-XD			3/8"	1-1/2"	60
5"	1-3/8"	275	W-75-XD			3/8"	1-3/4"	70
5"	2"	450/550		W-405-TD	W-405-PD	1/2"	2-5/16"	400
6"	1-5/8"	300	W-76-XD			3/8"	1-3/4"	70
6"	2"	500/600		W-406-TD	W-406-PD	1/2"	2-5/16"	400
8"	2"	500/600		W-408-TD	W-408-PD	1/2"	2-5/16"	400
<b>SUPER ROLL NEOPRENE WHEELS</b>								
2-1/2"	1"	75	W-22.5-XSR			5/16"	1-1/8"	20
2-1/2"	1"	150	W-32.5-XSR			5/16"	1-1/8"	30
2-1/2"	1-3/8"	175	W-62.5-XSR			3/8"	1-1/2"	60
3-1/2"	1-3/8"	225	W-63.5-XSR			3/8"	1-1/2"	60
4"	1-3/8"	225	W-64-XSR			3/8"	1-1/2"	60
4"	1-3/8"	300	W-74-XSR			3/8"	1-3/4"	70
5"	1-3/8"	275	W-65-XSR			3/8"	1-1/2"	60
5"	1-3/8"	350	W-75-XSR			3/8"	1-3/4"	70
6"	1-1/2"	400	W-76-XSR			3/8"	1-3/4"	70

## SOLID ELASTOMER WHEELS



W-406-PSE

### SOLID ELASTOMER TREAD SYMBOL "SE"<sup>™</sup> DUROMETER - SHORE 55 "D"

- Temperature Ranges -40°F to 230°F
- Resistant to Wide Range of Chemicals.
- A must for tow line applications.
- Extraordinarily easy to push.
- Shows minimal wear in extended use.
- Shock absorbing and extremely quiet.
- Resists abrasion and many hazardous chemicals.
- Displays extremely low heat build-up in continuous use.
- No maintenance required for precision bearings.
- No flat spotting.

### ROLLABILITY TESTS WITH DARCOR 'SE'<sup>™</sup> vs THE COMPETITION

Tests were conducted using a platform truck equipped with two swivel and two rigid 6 x 2 casters loaded with a total of 2150 pounds (537 per caster). The effort required to start and maintain the truck in motion was measured. The swivelling test was conducted by aligning the two swivel casters at 90° to the direction of travel.

Each test was conducted three times and the results averaged. Variations of twenty percent were common. The greatest variation was experienced when the forces required were greater than eighty pounds due to the physical effort required. All tests were conducted manually with appropriate force gauges, and roller bearings in the wheel.

The ranking of the various wheels gave the greatest weight to starting and rolling. It was felt that swivelling could be affected by the shape of the tread and would not be as valid an indication of performance.

### TEST RESULTS

RANK	MANUFACTURER & TYPE OF WHEEL	HARDNESS SHORE D	LOAD LBS	START LBS	ROLL LBS	SWIVEL LBS
#1	DARCOR Solid Wheel – SE <sup>™</sup>	55 <sup>D</sup>	2150	16	11	65
#2	DARCOR NEOPRENE	60-65 <sup>A</sup>	2150	26	24	115
#3	DARCOR Cast Iron Core – Cast Urethane	55	2150	34	25	120
#4	Competitor #1 Aluminium Core-Moulded Wheel	58	2150	35	25	130
#5	Competitor #2 Solid Wheel	60	2150	38	26	80
#6	Competitor #3 Thermoplastic Core – Thermoplastic Rubber	67 <sup>A</sup>	2150	43	27	117
#7	DARCOR Solid Wheel – Hard Rubber	78 <sup>D</sup>	2150	44	33	66
#8	Competitor #4 Aluminium Core – Cast Urethane	40-100	2150	44	38	145
#9	Competitor #5 Thermoplastic Core – Thermoplastic Urethane	50-60	2150	58	53	130
#10	Competitor #6 Thermoplastic Core – Thermoplastic Urethane	40-70	2150	63	49	130
#11	Competitor #7 Solid Wheel – Cast Urethane	60	2150	66	52	135
#12	Competitor #8 Aluminium Core – Thermoplastic Urethane	60	2150	120	90	150

the "SE"<sup>™</sup> WHEEL, is a proprietary blend of elastomers and other constituents to produce a wheel which is superior in performance to conventional urethane, hard rubber and Phenolic wheels.

THE TERM 'SE' IS A REGISTERED TRADEMARK OF DARCOR LIMITED.

## SOLID ELASTOMER WHEELS

WHEEL DIAMETER	TREAD WIDTH	LOAD CAPACITY	BALL BEARING	PRECISION SEALED BALL BEARING	BORE SIZE	HUB LENGTH	USED IN CASTER SERIES
2-1/2"	1-1/4"	300	W-62.5-XSE		3/8"	1-1/2"	60
3"	1-3/8"	500		W-73-PSE	3/8"	1-3/4"	70
	2"	900		W-403-PSE	1/2"	2-5/16"	400
3-1/2"	1-1/4"	350	W-63.5-XSE		3/8"	1-1/2"	60
4"	1-3/8"	600		W-74-PSE	3/8"	1-3/4"	70
	2"	1000		W-404-PSE	1/2"	2-5/16"	400
5"	1-3/8"	700		W-75-PSE	3/8"	1-3/4"	70
	2"	1000		W-405-PSE	1/2"	2-5/16"	400
	2-1/2"	1350		W-805-PSE	3/4"	2-3/4"	700/800
6"	1-3/8"	750		W-76-PSE	3/8"	1-3/4"	70
	2"	1100		W-406-PSE	1/2"	2-5/16"	400
	2-1/2"	1500		W-806-PSE	3/4"	2-3/4"	700/800
8"	2"	1200		W-408-PSE	1/2"	2-5/16"	400
	2-1/2"	1650		W-808-PSE	3/4"	2-3/4"	700/800
10"	2-1/2"	1800		W-810-TSE	3/4"	2-3/4"	700/800

### SOLID ELASTOMER EXTRA WEIGHT TREAD SYMBOL "SX" DUROMETER - SHORE 63 "D"

- Temperature Ranges -40°F to 230°F
- Withstand a 20% higher load and reduced swivelling and rolling forces than SE
  - Extraordinarily easy to push.
  - Shows minimal wear in extended use.
  - Shock absorbing and extremely quiet.
- Resists abrasion and many hazardous chemicals.
- Displays extremely low heat build-up in continuous use.
  - No maintenance required for precision bearings.
  - No flat spotting.



W-75-H

WHEEL DIAMETER	TREAD WIDTH	LOAD CAPACITY	BALL BEARING	PRECISION SEALED BALL BEARING	BORE SIZE	HUB LENGTH	USED IN CASTER SERIES
5"	2"	1200		W-405-PSX	1/2"	2-5/16"	400
6"	2"	1300		W-406-PSX	1/2"	2-5/16"	400
8"	2"	1400		W-408-PSX	1/2"	2-5/16"	400



## URETHANE WHEELS



**W-406-TU**

**URETHANE  
TREAD SYMBOL "U"  
DUROMETER - SHORE 95 "A"**

A Urethane Tread moulded and bonded to a steel core.  
Recommended for heavy loads and rough floor conditions.  
Resistant to a wide range of chemicals, oils and solvents.  
Withstands temperature ranges from 25°F below 0 up to 200°F.  
Resists abrasion and flat spotting.



**W-8510-YU**

**LOW EFFORT URETHANE  
TREAD SYMBOL "LE"  
DUROMETER - SHORE 80 "A"**

Glass reinforced nylon core  
Outperforms conventional urethane wheels  
Long lasting, resistant to chemicals  
Available in other hardness ratings  
Highly resilient  
Rolls smoothly on any floor material  
Suitable for wet applications



**W-405-PLE**

## URETHANE WHEELS

## URETHANE - U

WHEEL DIAMETER	TREAD WIDTH	LOAD CAP./LBS	ROLLER BEARING	TAPERED BEARING	BORE SIZE	HUB LENGTH	USED IN CASTER SERIES
3-1/2"	2"	800	W-403.5-TU		1/2"	2-5/16"	400
4"	1-3/8"	600	W-74-TU		3/8"	1-3/4"	70
4"	2"	900	W-404-TU		1/2"	2-5/16"	400
5"	1-3/8"	600	W-75-TU		3/8"	1-3/4"	70
5"	2"	1000	W-405-TU		1/2"	2-5/16"	400
6"	1-3/8"	600	W-76-TU		3/8"	1-3/4"	70
6"	2"	1000	W-406-TU		1/2"	2-5/16"	400
6"	2-1/4"	1500	W-806-TU		3/4"	2-3/4"	700/800
6"	3"	2500	W-5006-TU	W-5006-YU	3/4", 1"	3-3/8"	900, 5000, 5200
8"	2"	1000	W-408-TU		1/2"	2-5/16"	400
8"	2-1/2"	1800	W-808-TU		3/4"	2-3/4"	700/800
8"	3"	3000	W-5008-TU	W-5008-YU	3/4", 1"	3-3/8"	900, 5000, 5200
10"	3"	3500	W-5010-TU	W-5010-YU	3/4", 1"	3-3/8"	900, 5000, 5200
10"	4"	8000		W-8010-YU	1-1/2"	4-1/2"	WHEEL ONLY
10"	5"	10,000		W-8510-YU	1"	5-1/2"	SL-8510
12"	3"	4000	W-5012-TU	W-5012-YU	3/4", 1"	3-1/4"	900,5000,5200
16"	5"	8400		W-8016-YU	1-1/2"	5-1/2"	8216

Additional Bore Sizes available.

400 Series - 3/4"

700 Series - 1/2", 1"

5000 Series - 1-1/4"

## LOW EFFORT URETHANE - LE

WHEEL DIAMETER	TREAD WIDTH	LOAD CAPACITY	BALL BEARING	PRECISION SEALED BALL BEARING	BORE SIZE	HUB LENGTH	USED IN CASTER SERIES
4"	2"	630		W-404-PLE	1/2"	2-5/16"	400
6"	2"	700		W-406-PLE	1/2"	2-5/16"	400
8"	2"	700		W-408-PLE	1/2"	2-5/16"	400
8"	3"	2100		W-5008-PLE	3/4", 1"	3 3/8"	900, 5000, 5200

## SEMI-STEEL WHEELS

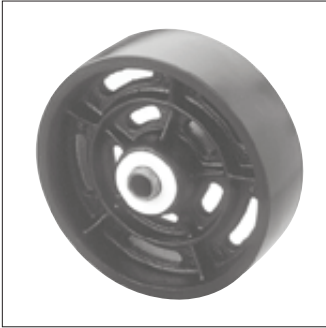

W-406-TCI

**SEMI-STEEL  
TREAD SYMBOL "CI"**

- Suitable for temperature ranges from -25 F to +500 F
- A Semi-Steel Casting of a close-grained high tensile iron
- Wheels are crowned to help prevent floor damage, and improve swiveling
- Able to carry the heaviest loads
- Also available in "Grooved" type for inverted angle iron applications
- Good chemical tolerance, resistance to glass or metal chips

WHEEL DIAMETER	TREAD WIDTH	LOAD CAP./LBS	SLEEVE BEARING	ROLLER BEARING	TAPERED BEARING	BORE SIZE	HUB LENGTH	USED IN CASTER SERIES
2"	1"	100	W-22-CI			5/16"	1-1/8"	20
2-1/2"	1"	125	W-22.5-CI			5/16"	1-1/8"	20
2-1/2"	1-1/4"	400	W-62.5-CI			3/8"	1-1/2"	60
3"	1-3/8"	400	W-63-CI			3/8"	1-1/2"	60
3"	1-3/8"	500	W-73-CI	W-73-TCI		3/8"	1-3/4"	70
3"	1-7/8"	900		W-403-TCI		1/2"	2-5/16"	400
3-1/2"	1-3/8"	400	W-63.5-CI			3/8"	1-1/2"	60
4"	1-3/8"	400	W-64-CI			3/8"	1-1/2"	60
4"	1-3/8"	600	W-74-CI	W-74-TCI		3/8"	1-3/4"	70
4"	1-7/8"	1000		W-404-TCI		1/2"	2-5/16"	400
5"	1-3/8"	400	W-65-CI			3/8"	1-1/2"	60
5"	1-3/8"	600	W-75-CI	W-75-TCI		3/8"	1-3/4"	70
5"	1-7/8"	1000		W-405-TCI		1/2"	2-5/16"	400
5"	2-1/4"	1500		W-805-TCI		3/4"	2-3/4"	700/800
6"	1-3/8"	600	W-76-CI			3/8"	1-3/4"	70
6"	1-7/8"	1000		W-406-TCI		1/2"	2-5/16"	400
6"	2-1/4"	1700		W-806-TCI		3/4"	2-3/4"	700/800
6"	3"	5000		W-5006-TCI	W-5006-YCI	3/4", 1"	3-3/8"	900, 5000, 5200
8"	1-7/8"	1000		W-408-TCI		1/2"	2-5/16"	400
8"	2-1/4"	1800		W-808-TCI		3/4"	2-3/4"	700/800
8"	3"	5000		W-5008-TCI	W-5008-YCI	3/4", 1"	3-3/8"	900, 5000, 5200
10"	2-1/4"	2200		W-810-TCI		3/4"	2-3/4"	700/800
10"	3"	5000		W-5010-TCI	W-5010-YCI	3/4", 1"	3-3/8"	900, 5000, 5200
12"	3"	5000		W-5012-TCI	W-5012-YCI	3/4", 1"	3-3/8"	900, 5000, 5200

Additional Bore Sizes available:

400 Series - 3/4"

700 Series - 1/2", 1"

5000 Series - 1-1/4"

## HARD RUBBER WHEELS

### HARD RUBBER TREAD SYMBOL "H" DUROMETER - SHORE 78 "D"

An extremely durable synthetic rubber material formed under very high pressure.  
Tremendous wearing characteristics.

NOT affected by oil, grease, water, gas or cleaning compounds.  
Non-Conductive.

Temperature range 110°F max. to -40°F.

Not recommended for use on tile.

Identification: Brown in colour.



**W-75-H**

WHEEL DIAMETER	TREAD WIDTH	LOAD CAP./LBS	SLEEVE BEARING	BALL BEARING	BORE SIZE	HUB LENGTH	USED IN CASTER SERIES
2"	1"	100	W-22-H	W-22-XH	5/16"	1-1/8"	20
2"	1"	150		W-32-XH	5/16"	1-1/8"	30
2-1/2"	1"	125	W-22.5-H		5/16"	1-1/8"	20
2-1/2"	1"	150		W-32.5-XH	5/16"	1-1/8"	30
3"	1"	125	W-23-H		5/16"	1-1/8"	20
3"	1-3/8"	350	W-63-H		3/8"	1-1/2"	60
3"	1-3/8"	500	W-73-H		3/8"	1-3/4"	70
3-1/2"	1-3/8"	375	W-63.5-H		3/8"	1-1/2"	60
4"	1"	125	W-24-H		5/16"	1-1/8"	20
4"	1-3/8"	400	W-64-H		3/8"	1-1/2"	60
4"	1-3/8"	550	W-74-H		3/8"	1-3/4"	70
5"	1-3/8"	400	W-65-H		3/8"	1-1/2"	60
5"	1-3/8"	600	W-75-H		3/8"	1-3/4"	70
6"	1-3/8"	600	W-76-H		3/8"	1-3/4"	70

## GLOSSARY OF TERMS

<b>ABRASION RESISTANCE:</b>	The ability of a wheel to resist wear due to use with various floor materials.
<b>AXLE &amp; NUT:</b>	Retains wheels in the yoke.
<b>BOLT HOLE SPACING:</b>	The distance from the centre of one bolt hole to the centre of the next. Where slotted bolt holes are used, two dimensions will be shown.
<b>BORE SIZE:</b>	The axle diameter required for installing a wheel.
<b>CASTER:</b>	One complete unit consisting of all basic caster components: top plate, yoke, wheel, wheel bearing, thread guards, axle nut and washer.
<b>CHEMICAL RESISTANCE:</b>	The degree to which a wheel or tread material is affected when exposed to chemicals.
<b>COMPLETE WHEEL:</b>	The wheel, wheel bearing and related parts, and thread guards.
<b>COMPRESSION SET:</b>	(Also referred to as set or flat spotting.) The effect on a wheel, under load, after a given period of time.
<b>CONDUCTIVE WHEELS:</b>	Measurement of a wheel material's ability to dissipate static electricity (as in anti-static or spark proof wheels).
<b>CROWN:</b>	The Radius molded or machined on the periphery of the wheel to reduce swivelling effort.
<b>DUROMETER (HARDNESS):</b>	System for establishing how hard or soft a wheel is. Measured as shore hardness on either the "A" scale for softer tread materials, or the "D" scale for harder tread materials.
<b>DUSTCAP:</b>	Encloses the hardcap to protect the raceway from foreign materials.
<b>DYNAMIC LOAD:</b>	The maximum load on a caster in motion under normal conditions.
<b>ERGONOMICS:</b>	A way of thinking about the design of tools and equipment, the layout of workplaces, and the overall organization of work. The goal of ergonomics is the realization of production and health/safety benefits by fitting the job to the person rather than making the person fit the job.
<b>FLAT SPOT:</b>	Lower quality wheels may develop these 'flat spots' when sitting with a heavy load for a period of time. Once a flat spot has developed the mobility of the wheel is greatly decreased.
<b>HARDCAP:</b>	The thrust bearing upper raceway.
<b>HUB LENGTH:</b>	The distance from one edge of the hub (axle opening) to the other.
<b>KING BOLT OR RIVET:</b>	Holds swivel components together. A King Bolt is threaded with a nut tightened over the lower end of the swivel. A rivet is either staked through, or orbitally connected to the swivel.
<b>LOAD CAPACITY:</b>	The recommended maximum weight to be carried by a single caster or wheel.
<b>MOBILITY:</b>	Defines the degree of freedom of movement.
<b>OVERALL HEIGHT:</b>	The vertical distance between the top of the caster mounting plate and the bottom of the wheel. When using a stem, this dimension is reduced by the thickness of the top plate.
<b>RESILIENCY:</b>	The amount of spring or bounce in a wheel and the resulting effect on rolling resistance.
<b>RIG:</b>	The partially assembled metal portion of the caster that has not yet had a wheel installed
<b>RIGID CASTER:</b>	A basic caster unit which does not swivel.
<b>ROLLING RESISTANCE:</b>	The amount of effort required to move a load usually measured in pounds of force.
<b>SHOCK LOAD:</b>	The maximum load a caster can withstand under shock conditions.
<b>SHORE:</b>	The measurement scale used to determine how hard a material is. Also see 'Durometer'
<b>SOLID ELASTOMER:</b>	A breakthrough advance in wheel technology, exclusive to Darcor. Solid elastomer wheels are renowned for low rolling resistance, imperviousness to harsh chemicals, and perfect shape retention even after long-term exposure to temperature and load extremes.
<b>STATIC LOAD:</b>	The maximum load on a caster when movement or shock are not present.
<b>SWIVEL CASTER:</b>	A basic caster unit with the addition of a bearing that allows the caster to swivel about a vertical axis.
<b>SWIVEL RACEWAY:</b>	The part of the swivel that contains the bearings.
<b>SWIVEL RADIUS:</b>	The radius required for a caster to swivel freely. Determined by measuring from the centre of the King Bolt to the outside of the wheel.
<b>TEMPERATURE RANGE:</b>	The maximum temperature range that a wheel can operate within for a period of time and still maintain its characteristics.
<b>THREAD GUARDS:</b>	(Also known as string guards.) Keep foreign materials away from axle and bearings.
<b>TOP PLATE OR STEM:</b>	Elements for attaching a caster to a piece of equipment.
<b>TOP PLATE SIZE:</b>	Determined by measuring from one outside edge to the other outside edge.
<b>TREAD WIDTH:</b>	The distance between the outermost edges of the wheel.
<b>WHEEL BEARINGS:</b>	Various types of bearings available.
<b>WHEEL SIZE:</b>	Determined by the diameter of the wheel.
<b>YOKE:</b>	Supports upper and lower raceways. A rigid yoke is either a top plate with legs welded to it or a formed, single-piece top plate/yoke combination.

We are proud of the casters we manufacture. Visit our manufacturing facilities and you will see the evidence of that pride in the care and attention to detail focused on each caster – from the design stage, through production, to shipping and after-sale service. To some, quality control is a marketing strategy; to us, it is a way of business life. That is why our comprehensive line of casters has won a worldwide reputation for reliability, longevity and, perhaps most importantly, usefulness.

We manufacture a wide variety of casters, ranging from the Carpet Master office chair caster to our heaviest casters rated to a load capacity of 60,000 lbs. In between, you'll find ... well, casters of almost any size or style you can imagine.

The reason for all these choices is not to fill catalogue pages. It is to ensure we can provide you with the bolt-hole pattern, the caster size and height, the wheel material that is perfectly useful for your needs.

And, if we can't deliver what you need from stock, we'll be happy to design and manufacture a specialty caster that delivers maximum usefulness. And we'll do it quickly, efficiently and economically. (We're flexible that way – your way!)

What sets us apart from other caster manufacturers is people. Sure, we have state-of-the-art design and manufacturing systems and processes. Certainly, our quality controls and strict adherence to technical specifications are second to none. But it is the caliber of our dedicated and versatile employees which has allowed Darcor to establish a standard of excellence that is far above the rest.

#### **PERSONAL CUSTOMER SERVICE**

Our customer service personnel are experienced professionals. They know casters and can match our products to your needs. If you have any questions about specifications, pricing, delivery information or any wheel or caster listed in this catalogue, just give our "problem solvers" a call. They'll be happy to get you moving the best possible way: on a Darcor caster.

#### **OUR GUARANTEE**

Every Darcor product is warranted against defects in material and workmanship for a period of three years from the date of original purchase. Any product defective because of material or workmanship returned with the prior written approval of Darcor's Quality Control Department, within the warranty period, will be repaired or replaced, free of charge, non-inclusive of freight and installation, if delivered, transportation and shipping charged prepaid, to Darcor factory located at 7 Staffordshire Place, Toronto, Ontario M8W 1T1. This guarantee does not include any product that has been abused, misused, improperly installed, mishandled, not used for the purpose intended, used under severe or adverse conditions.



#### **DESIGNS**

Dimensions and designs are subject to change without notice.

#### **RETURN GOODS POLICY**

Return goods shipment requires prior authorization and a return goods number from Darcor.

A charge will be applied to cover the handling and restocking, providing goods are resaleable and do not require refurbishing.

No cancellations after the start of production.

No specially manufactured casters may be returned.

**DARCOR**  
CASTERS AND WHEELS

**CORPORATE HEADQUARTERS**  
7 STAFFORDSHIRE PLACE  
TORONTO, ONTARIO CANADA  
M8W 1T1

T: 416.255.8563

F: 416.251.6117

[www.darcor.com](http://www.darcor.com)



# DARCOR

CASTERS AND WHEELS

Darcor Limited - 7 Staffordshire Place, Toronto, Ontario, Canada - M8W 1T1 - Tel:416.255.8563 - Fax:416.251.6117

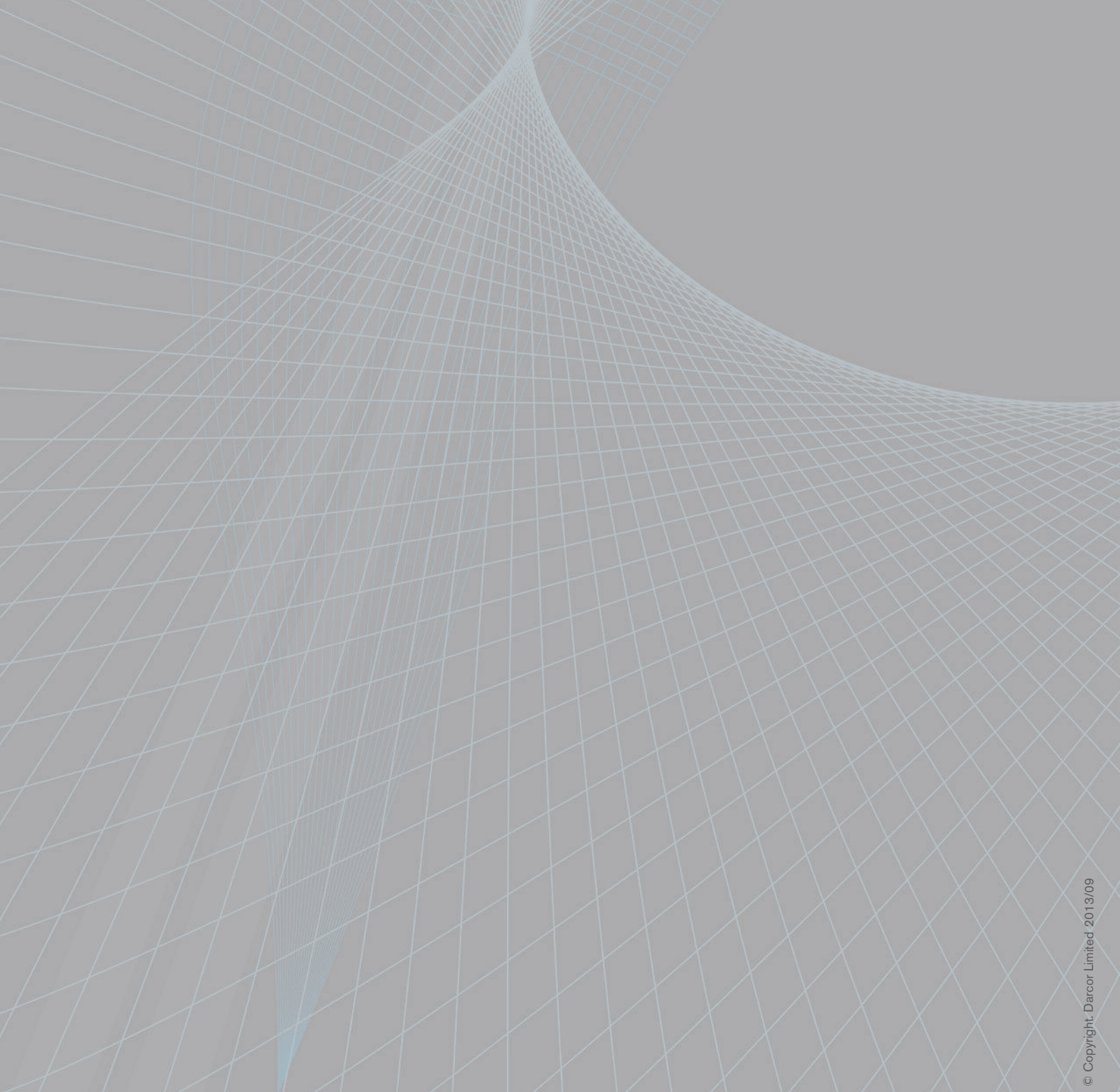

© Copyright Darcor Limited 2013/09